

INFORMAZIONI GENERALI

Il presente catalogo serve per richiedere con esattezza le parti di ricambio
Nelle ordinazioni indicare:

- 1) il numero di codice dei particolari seguito dalla descrizione;
 - 2) il colore per i pezzi verniciati o comunque colorati;
 - 3) il numero di matricola del motociclo, stampigliato sul canotto di sterzo.
- Le indicazioni destra e sinistra si riferiscono ai lati del veicolo rispetto al senso di marcia.

GENERAL INFORMATION

The present spare parts list enables one to order exactly the right spare parts.

When ordering specify:

- 1) the part's code number followed by its description;
 - 2) indicate colour for painted or coloured parts;
 - 3) the motorcycle's serial number, stamped on the steering head.
- References to right and left apply to the vehicle in terms of its direction of movement.

INFORMATIONS GENERALES

Ca catalogue permet de commander correctement les pièces de rechange.

Les commandes doivent être passées en indiquant:

- 1) le numéro de code des pièces détachées suivi de leur description;
 - 2) le couleur des pièces peintes ou colorés;
 - 3) le matricule de la moto, estampillé sur la tige du guidon.
- Droite et gauche sont les côtés du véhicule par rapport au sens de la marche.

ALLGEMEINE HINWEISE

Dieser Ersatzteilkatalog dient zur genauen Angabe der Teile bei Ersatzteilbestellungen.

Bei Ersatzbestellung ist folgendes anzugeben:

- 1) Die Bestellnummer der Ersatzteile mit der entsprechenden Beschreibung;
 - 2) Farbe für lackierte und farbige Teile angeben;
 - 3) Die Sseriennummer des Motorrads, die am Lenkrohr eingepägt ist.
- Die Angaben rechts und links beziehen sich auf das Fahrzeug in Fahrriichtung.

INFORMACIONES GENERALES

El presente catálogo sirve para pedir con exactitud las partes de recambio.

En los pedidos se debe indicar:

- 1) el número de código de la parte y a continuación la descripción;
 - 2) el color para las piezas barnizadas o coloreadas;
 - 3) el número de matrícula de la motocicleta, estampado en le tubo de dirección.
- Las indicaciones derecha e izquierda se refieren a los lados del vehículo respecto del sentido de marcha.

NOTE - LIST - NOTES - NOTE - NOTAS:

- A** : In alternativa - In alternative - En alternative
Wahlweise - En alternativa
 - C** : Modello CR- CR model - Modéle CR - Modell CR
Modélo CR
 - D** : In dotazione - To issue - En necessaire
Ausrustungsteile - En dotaciòn
 - E** : Ad esaurimento - To fell out - A' finir - Erschöpfung - A agotamiento
 - F** : Fornire assieme - Supply unitedly - Fournir ensemble
Wird zusammen geliefert - Equipar juntos
 - N** : Non fornito - Not supplied - Ne pas fournit
Keine Gelieferende - No equiparado
 - R** : A richiesta - Upon request - Sur demande
Auf anfrage - Bajo pedido
 - S** : Di serie - Supplied - De série - Standard - De serie
 - U** : Solo per WR U.S.A. - Only for WR U.S.A.- Soulement pour
WR U.S.A. - Nur für WR U.S.A. - Solo por WR U.S.A.
 - X** : Non per U.S.A. - Not for U.S.A. - Ne pas pour U.S.A.
Keine für U.S.A. - No por U.S.A.
 - Y** : Non per CR - Not for CR - Ne pas pour CR
Keine für CR - No por CR
 - XBR** : Non per Brasile- Not for Brazil - Ne pas pour Brasile
Keine für Brasilien - No por Brasil
 - W** : Modello WR- WR model - Modéle WR - Modell WR
Modélo WR
 - Z** : n° denti, number of teeth, numéro dents, Zähne nummer,
número dientes
- (&), (@), (*), (\$):** Montati assieme- Assembled together

- A** : Austria, Austria, Autriche, Österreich, Austria
- AUS** : Australia, Australia, Australie, Australien, Australia
- B** : Belgio, Belgium, Belgique, Belgien, Bélgica
- BR** : Brasile, Brazil, Brasile, Brasilien, Brasil
- CDN** : Canada, Canada, Canada, Kanada, Canadá
- CH** : Svizzera, Switzerland, Suisse, Schweizer, Suiza
- D** : Germania, Germany, Allemagne, Deutschland, Alemania
- E** : Spagna, Spain, Espagne, Spanien, España
- F** : Francia, France, France, Frankreich, Francia
- GB** : Gran Bretagna, Great Britain, Grand Bretagne
Groos Britan, Gran Bretaña
- I** : Italia, Italy, Italie, Italien, Italia
- J** : Giappone, Japan, Japon, Japan, Japón
- SF** : Finlandia, Finald, Finlande, Finnland, Finlandia
- USA** : Stati Uniti d'America, United States of America
Etats Units d'Amerique,
Vereinigte Staaten von Amerika, Estados Unidos

N° DI MATRICOLA INIZIALE - INITIAL SERIAL NUMBER - MATRICULE INITIAL - BEGINNTESERIENNUMMER - MATRICULA INICIAL	
MODELLO - MODEL MODELE - MODELL MODELO	MATRICOLA - SERIAL NUMBER MATRICULE - SERIENNUMMER MATRICULA
WR 125/2013	ZKH4H00AADV000001
WR USA 125/2013	ZKHWR123#DV000000
CR 125/2013	ZKH4H00AADV050001
CR USA 125/2013	ZKHCR123#DV000000

Tavola Drawing Table Bild Tabla	Denominazione	Description	Designation	Bezeichnung	Denominacion	Pagina Page Seite Paja
1	ATTREZZI DI ASSISTENZA	SERVICE TOOLS	OUTILS D'ASSISTANCE	HILFAUSRUSTUNG	HERRAMIENTAS DE ASISTENCIA	
2	TESTA, CILINDRO, PISTONE, MANOVELLISMO	CYLINDER HEAD, CYLINDER, PISTON, CRANKSHAFT	CULASSE, CYLINDRE, PISTON, VILEBREQUIN	ZYLINDERKOPF, ZYLINDER, KOLBEN, KURBELWELLE	CULATA, CILINDRO, PISTON, PALANCAS	15
3	H.T.S.	H.T.S.	H.T.S.	H.T.S.	H.T.S.	21
4	RAFFREDDAMENTO (CR)	COOLING SYSTEM (CR)	REFROIDISSEMENT (CR)	WASSERKÜHLUNG (CR)	ENFRIAMIENTO (CR)	25
4A	RAFFREDDAMENTO (WR)	COOLING SYSTEM (WR)	REFROIDISSEMENT (WR)	WASSERKÜHLUNG (WR)	ENFRIAMIENTO (WR)	27
5	BASAMENTO	CRANKCASE	CARTER	GEHAUSE	BANCADA	29
6	COPERCHI BASAMENTO	CRANKCASE COVERS	COUVERCLES CARTER	GEHAUSEDECKEL	TAPA BANCADA	35
7	FRIZIONE, TRASM. PRIMARIA	CLUTCH, PRIMARY DRIVE	EMBAYAGE, TRANSMISS. PRIMARIE	KUPPLUNG, ERSTERANTRIEB	ENBRAGUE	37
8	CAMBIO	TRANSMISSION	BOITE DE VITESSE	WECHSELGETRIEBE	CAMBIO	39
9	COMANDO CAMBIO	SHIFTER	COMMANDE DE VITESSE	GANGSCHALTUNG	MANDO CAMBIO	41
10	PARTE ELETTRICA (WR)	ELECTRIC PART (WR)	PARTIE ELECTRIQUES (WR)	ELEKTRISCHETEILE (WR)	PARTE ELECTR. (WR)	43
10A	PARTE ELETTRICA (CR)	ELECTRIC PART (CR)	PARTIE ELECTRIQUES (CR)	ELEKTRISCHETEILE (CR)	PARTE ELECTR. (CR)	45
11	AVVIAMENTO A PEDALE	KICK STARTER	PEDAL DE MISE EN MARCHÉ	ANLASSER	PUESTA EN MARCHA A PEDAL	47
12	CARBURATORE	CARBURETOR	CARBURATEUR	VERGASER	CARBURADOR	49
13	FILTRO ARIA	AIR FILTER	FILTRE AIRE	AIRFILTER	FILTRO DE AIRE	53
14	TELAIO, PEDANE	FRAME, FOOT RESTS	CADRE, REPOSE PIEDS	RAHMEN, FUSSBRETT	BASTIDOR, REPOSAPIES	55
15	SOSPENSIONE ANTERIORE (WR)	FRONT FORK ASSEMBLY (WR)	SUSPENSION AVANT (WR)	VORDERTELESKOPGABEL (WR)	SUSPENSION DELANTERA (WR)	59
15A	SOSPENSIONE ANTERIORE (CR)	FRONT FORK ASSEMBLY (CR)	SUSPENSION AVANT (CR)	VORDERTELESKOPGABEL (CR)	SUSPENSION DELANTERA (CR)	63
16	FORCELLONE	SWING ARM	FOURCHE ARRIERE	HINTERGABEL	HORQUILLA TRASERA	67
16A	LEVERAGGI SOSPENSIONE POSTERIORE	REAR SUSPENSION LINKAGE	LEVIER SUSPENSION ARRIERE	HEBELWERK HINTERHAUFHANGUNG	PALANCA SUSPENSION TRASERA	71
16B	AMMORTIZZATORE POSTERIORE	REAR SHOCK ABSORBER	AMMORTISSEUR ARRIERE	HINTERSTOSSDAMPFER	AMORTIGUADOR TRASERO	73
17	MANUBRIO E COMANDI	HANDLEBAR AND CONTROLS	GUIDON ET COMMANDES	LENKER UND STEUERORGANE	MANILLAR Y MANDOS	75
18	FRENO IDRAULICO POSTERIORE	REAR HYDRAULIC BRAKE	FREIN HYDRAULIQUE ARRIERE	HINTERBREMSE	FRENO HIDRAULICO TRASERO	77
19	PANNELLI LATERALI, PORTATARGA PARAFANGHI, SELLA	SIDE PANELS, FENDERS, SEAT PLATE HOLDER	PANNEAU, GARDE-BOUES , SIEGE, PORTE-BALAI	STREIFEN, KOTFLUGEL, SATTEL SCHILDTRÄGER	PANELES, GUARDABARROS, SILLIN, PORTAMATRICULA	79
20	SERBATOIO CARBURANTE, CONVOGLIATORI	GAS TANK, PANELS	RESERVOIR CARBURANT, FLANCS	KRAFTSTOFFBEHALTER, FLANKE	DEPOSITO GASOLINA, LATERALES	83
21	SCARICO	EXHAUST SYSTEM	TUYAU D'ÉCHAPPEMENT	AUSPUFFROHR	TUBO DE ESCAPE	85
22	FRENO IDRAULICO ANTERIORE	FRONT HYDRAULIC BRAKE	FREIN HYDRAULIQUE AVANT	VORTERBREMSE	FRENO HIDRAULICO DELANTERO	87
23	RUOTA ANTERIORE	FRONT WHEEL	ROUE AVANT	VORTERRAD	RUEDA DELANTERA	89
24	RUOTA POSTERIORE	REAR WHELL	ROUE ARRIERE	HINTERRAD	RUEDA TRASERA	91

Tavola Drawing Table Bild Tabla	Denominazione	Description	Designation	Bezeichnung	Denominacion	Pagina Page Page Seite Paja
25	STRUMENTO DIGITALE, INDICATORI AVVISATORE ACUSTICO	DIGITAL INSTRUMENT, BLINKERS, HORN	INSTRUMENT DIGITAL, CLIGNOTANTS, SIGNALATEUR ACOUSTIQUE	DIGITAL TACHOMETER, BLINKERS, HUPE	INSTRUMENTO DIGITAL, INTERMITENTES AVISADOR ACUSTICO	93
26	GRUPPO CAVI, PARTI ELETTRICHE	MAIN WIRING HARNESS, ELECTRICAL PARTS	CABLES PRINCIPAL, PARTIES ELECTRIQUES	KABEL, ELEKTRISCHE KOMPONENTE	GRUPO PRINCIPAL CABLES, PARTES ELECTRICAS	95
27	DECALCOMANIE (WR)	TRANSFERS (WR)	DECAL. (WR)	ABZIEHBILD (WR)	CALCOMANIA (WR)	97
28	DECALCOMANIE (CR)	TRANSFERS (CR)	DECAL. (CR)	ABZIEHBILD (CR)	CALCOMANIA (CR)	99
29	DOTAZIONE	EQUIPMENT	EQUIPEMENT	DOTIERUNG	EQUIPAMIENTO	101

Tavola - Drawing - Table - Bild - Tabla

6

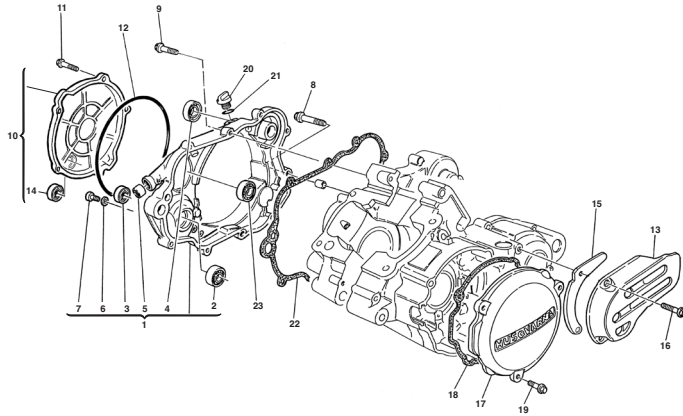

Pagina - Page - Page - Seite - Paja

34

Tavola - Drawing - Table - Bild - Tabla

7

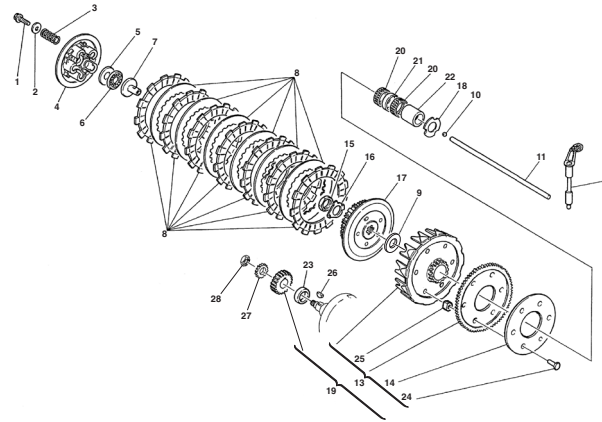

Pagina - Page - Page - Seite - Paja

36

Tavola - Drawing - Table - Bild - Tabla

8

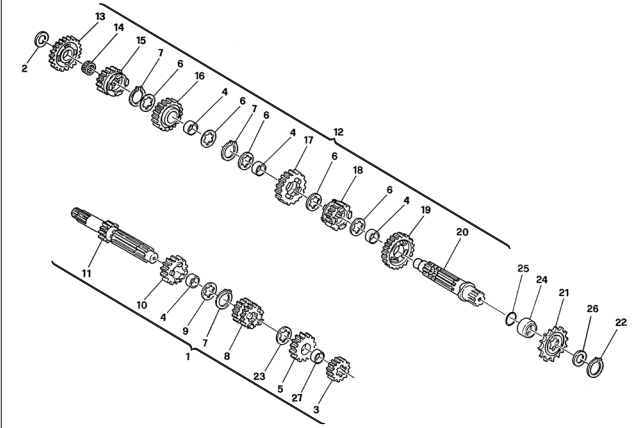

Pagina - Page - Page - Seite - Paja

38

Tavola - Drawing - Table - Bild - Tabla

9

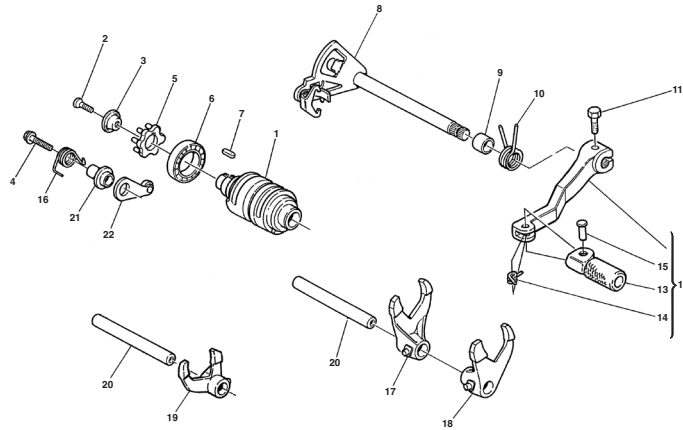

Pagina - Page - Page - Seite - Paja

40

Tavola - Drawing - Table - Bild - Tabla

10

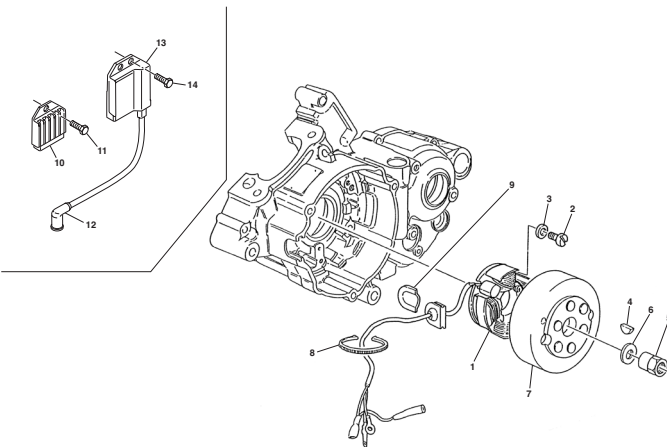

Pagina - Page - Page - Seite - Paja

42

Tavola - Drawing - Table - Bild - Tabla

10A

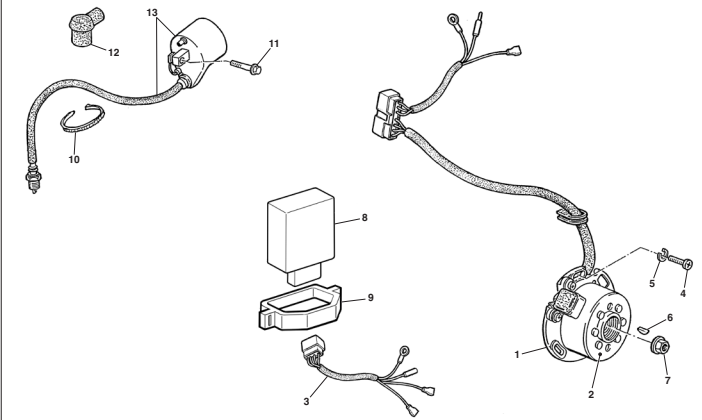

Pagina - Page - Page - Seite - Paja

44

Tavola - Drawing - Table - Bild - Tabla

11

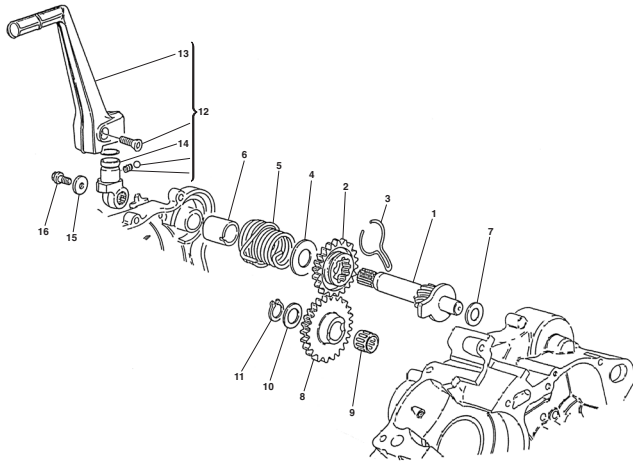

Pagina - Page - Page - Seite - Paja

46

Tavola - Drawing - Table - Bild - Tabla

12

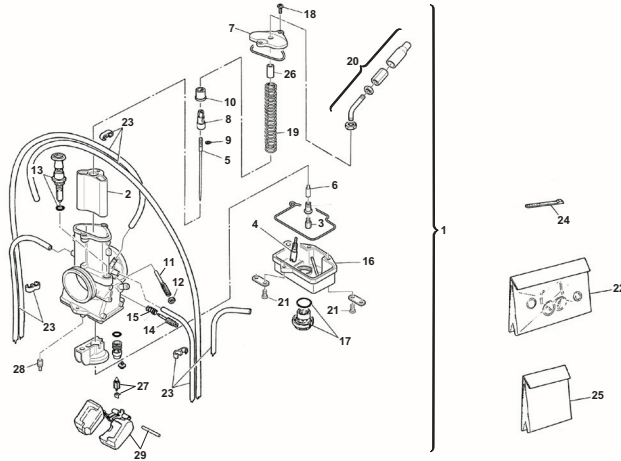

Pagina - Page - Page - Seite - Paja

48

Tavola - Drawing - Table - Bild - Tabla

13

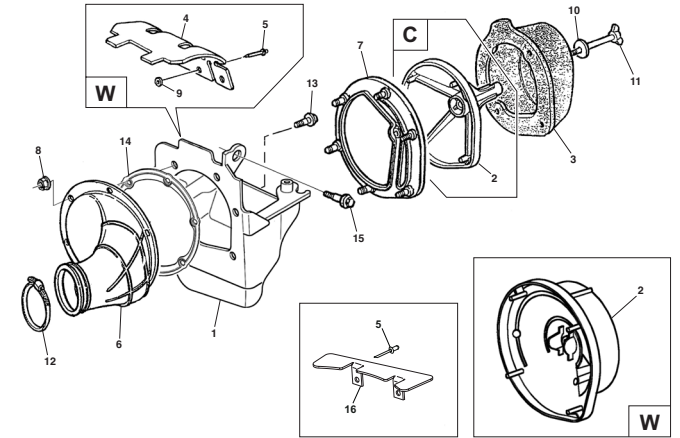

Pagina - Page - Page - Seite - Paja

52

Tavola - Drawing - Table - Bild - Tabla

14

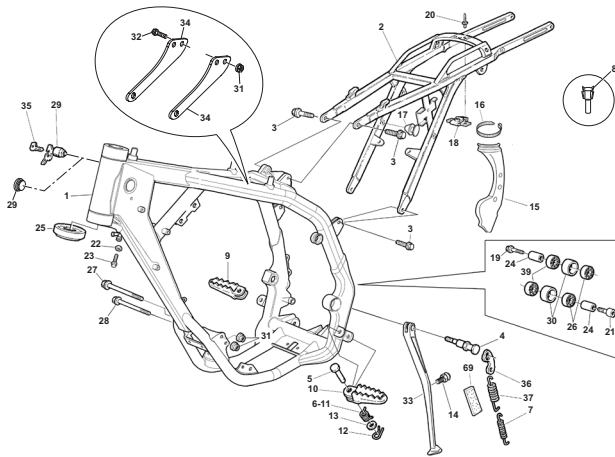

Pagina - Page - Page - Seite - Paja

54

Tavola - Drawing - Table - Bild - Tabla

15

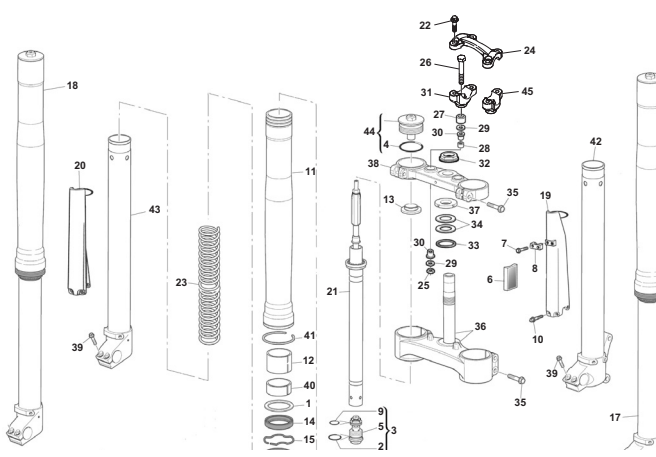

Pagina - Page - Page - Seite - Paja

58

Tavola - Drawing - Table - Bild - Tabla

15A

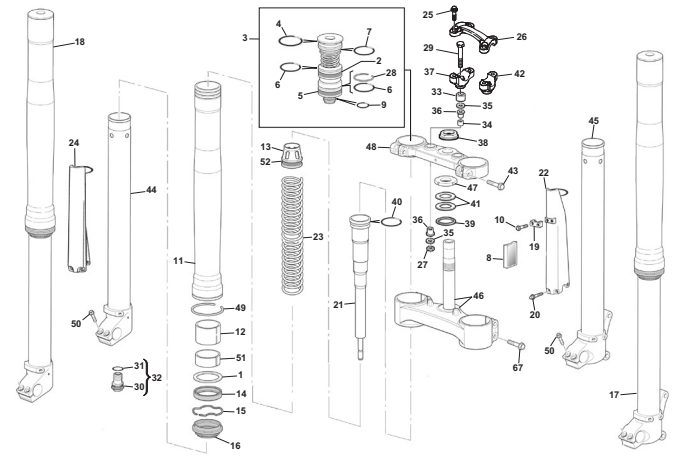

Pagina - Page - Page - Seite - Paja

62

Tavola - Drawing - Table - Bild - Tabla

16

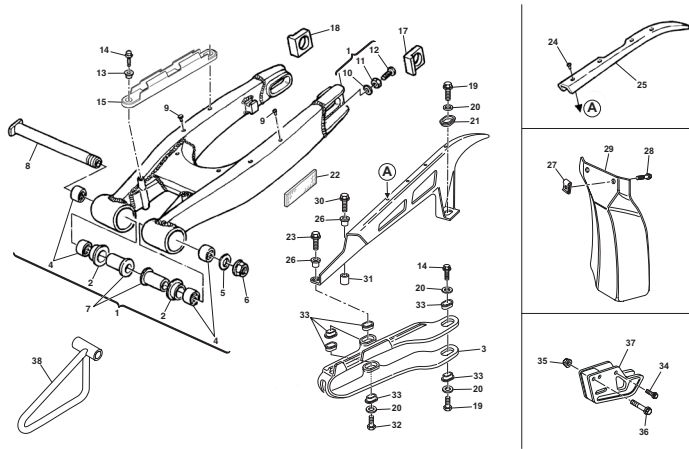

Pagina - Page - Page - Seite - Paja

66

Tavola - Drawing - Table - Bild - Tabla

16A

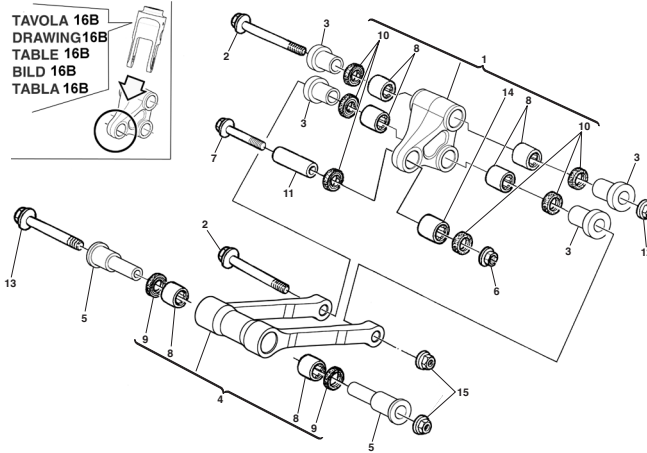

Pagina - Page - Page - Seite - Paja

70

Tavola - Drawing - Table - Bild - Tabla

16B

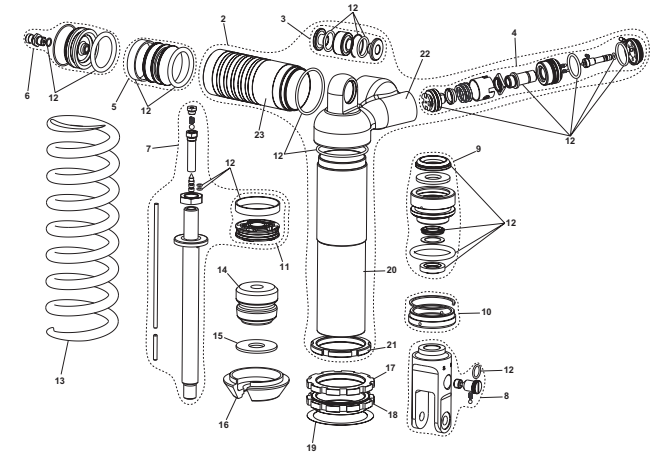

Pagina - Page - Page - Seite - Paja

72

Tavola - Drawing - Table - Bild - Tabla

17

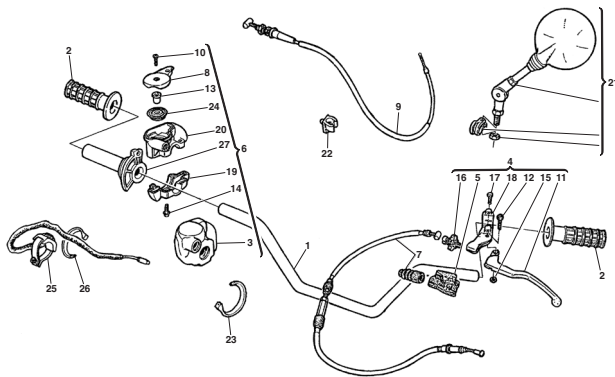

Pagina - Page - Page - Seite - Paja

74

Tavola - Drawing - Table - Bild - Tabla

18

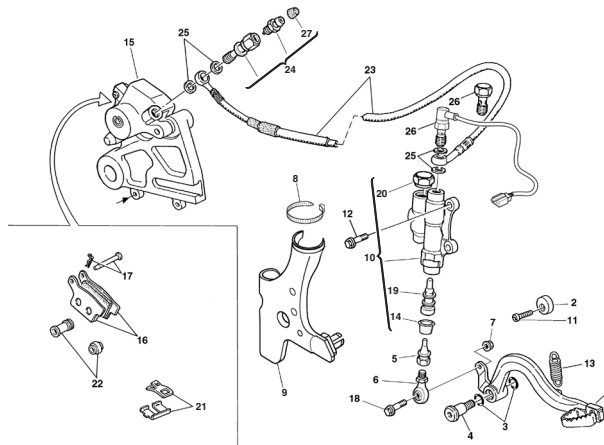

Pagina - Page - Page - Seite - Paja

76

Tavola - Drawing - Table - Bild - Tabla

19

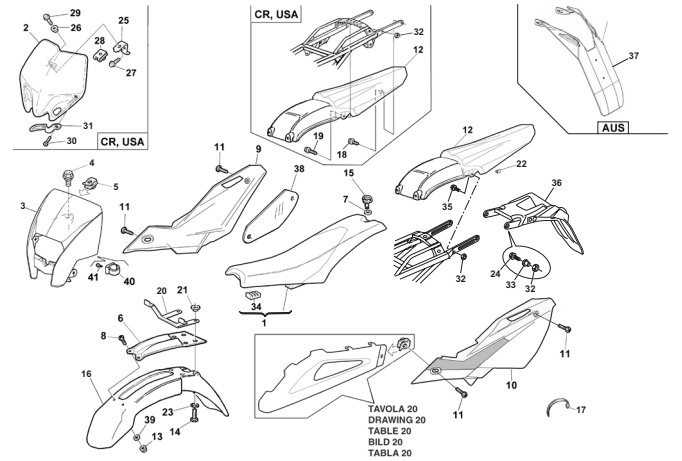

Pagina - Page - Page - Seite - Paja

78

Tavola - Drawing - Table - Bild - Tabla

20

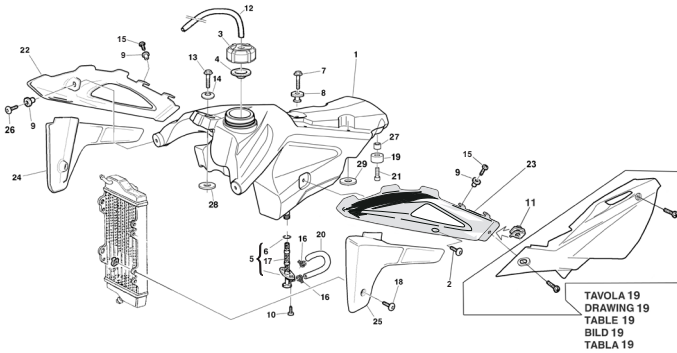

Pagina - Page - Page - Seite - Paja

82

Tavola - Drawing - Table - Bild - Tabla

21

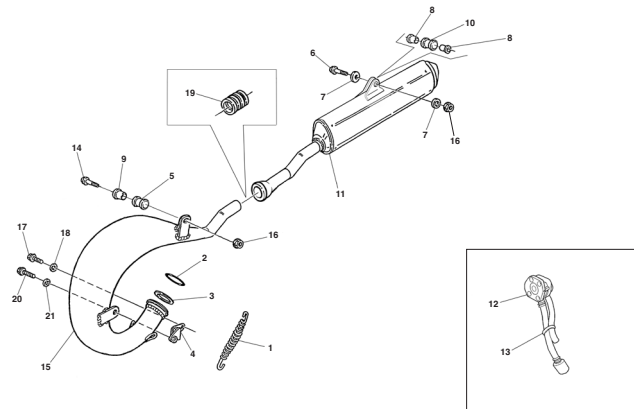

Pagina - Page - Page - Seite - Paja

84

Tavola - Drawing - Table - Bild - Tabla

22

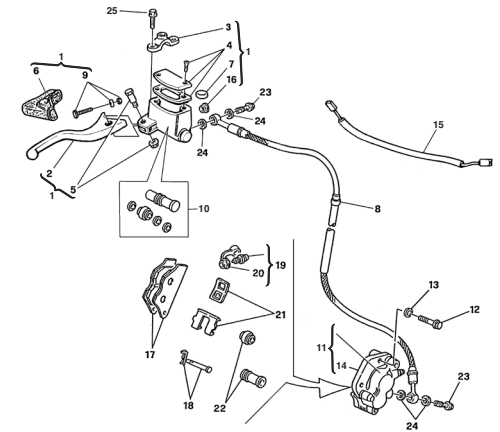

Pagina - Page - Page - Seite - Paja

86

Tavola - Drawing - Table - Bild - Tabla

23

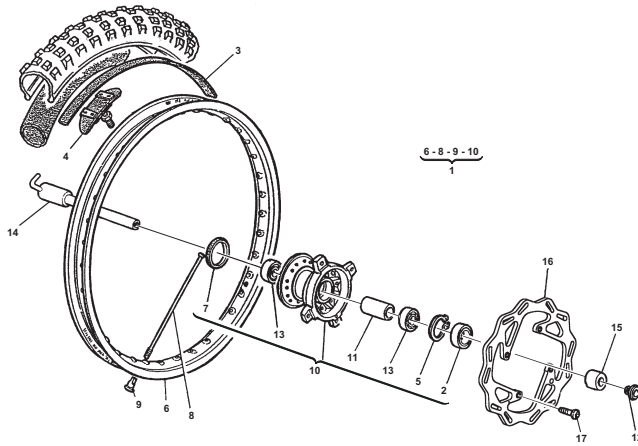

Pagina - Page - Page - Seite - Paja

88

Tavola - Drawing - Table - Bild - Tabla

24

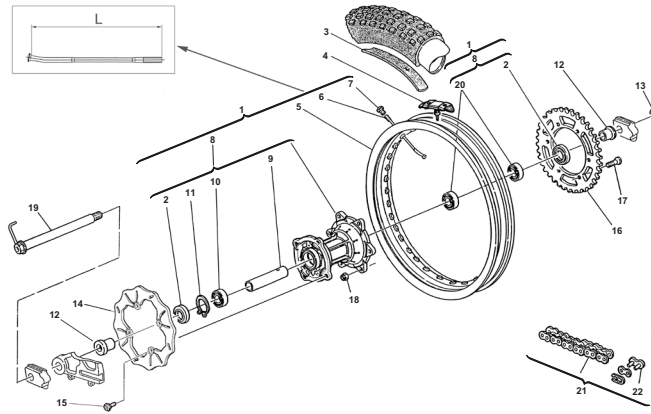

Pagina - Page - Page - Seite - Paja

90

Tavola - Drawing - Table - Bild - Tabla

25

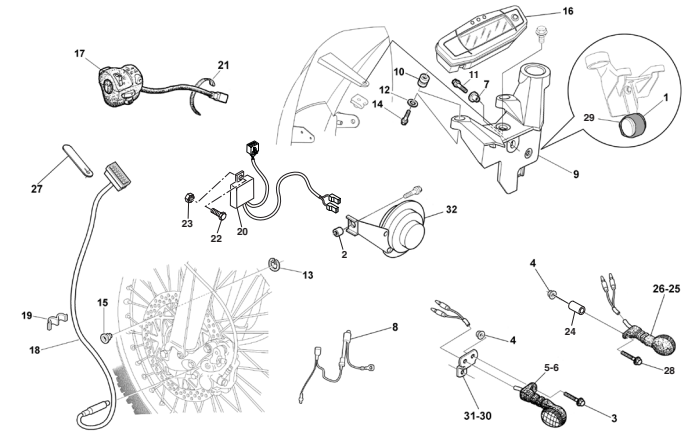

Pagina - Page - Page - Seite - Paja

92

Tavola - Drawing - Table - Bild - Tabla

26

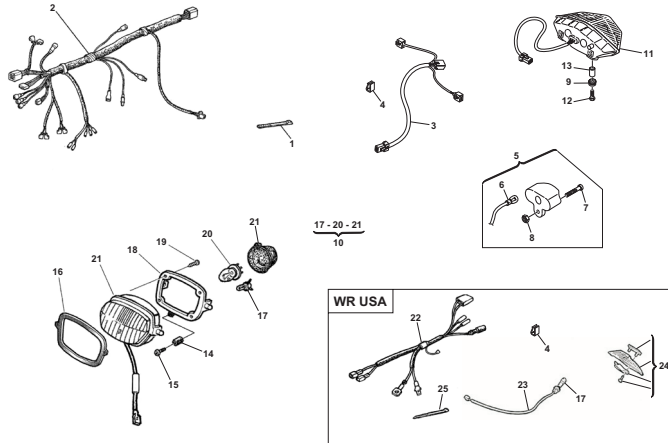

Pagina - Page - Page - Seite - Paja

94

Tavola - Drawing - Table - Bild - Tabla

27

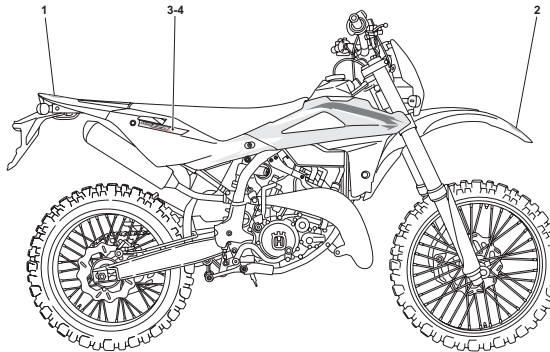

Pagina - Page - Page - Seite - Paja

96

Tavola - Drawing - Table - Bild - Tabla

28

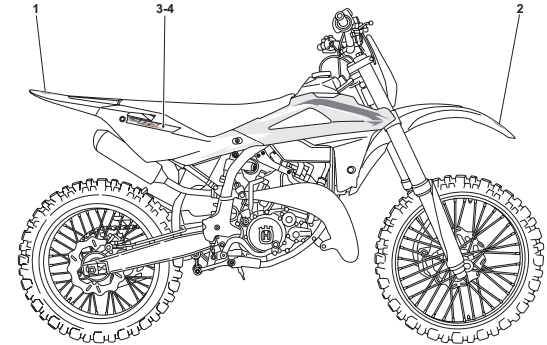

Pagina - Page - Page - Seite - Paja

98

Tavola - Drawing - Table - Bild - Tabla

29

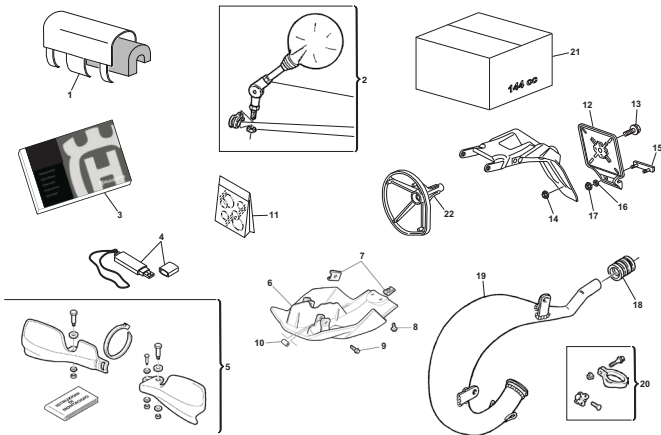

Pagina - Page - Page - Seite - Paja

100



Husqvarna[®]

**PAGINA INTENZIONALMENTE BIANCA
INTENTIONALLY WHITE PAGE**

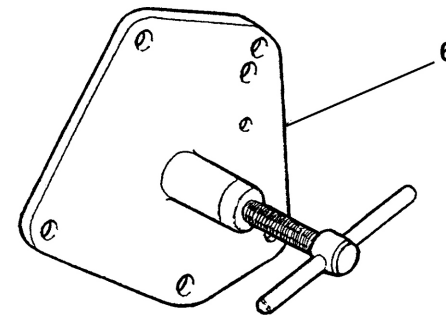
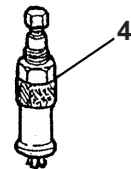
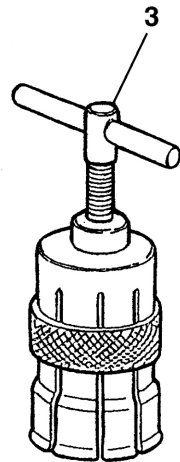
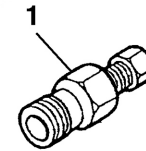
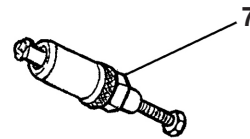
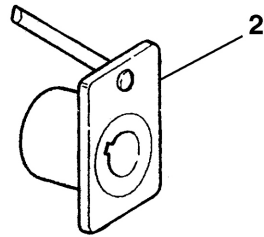
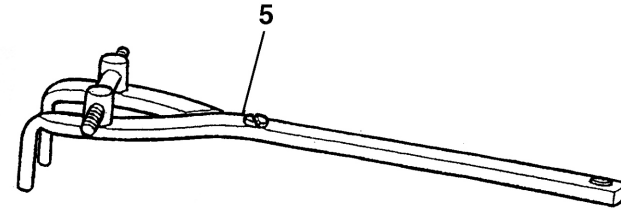
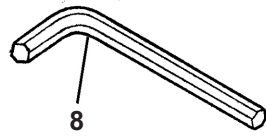

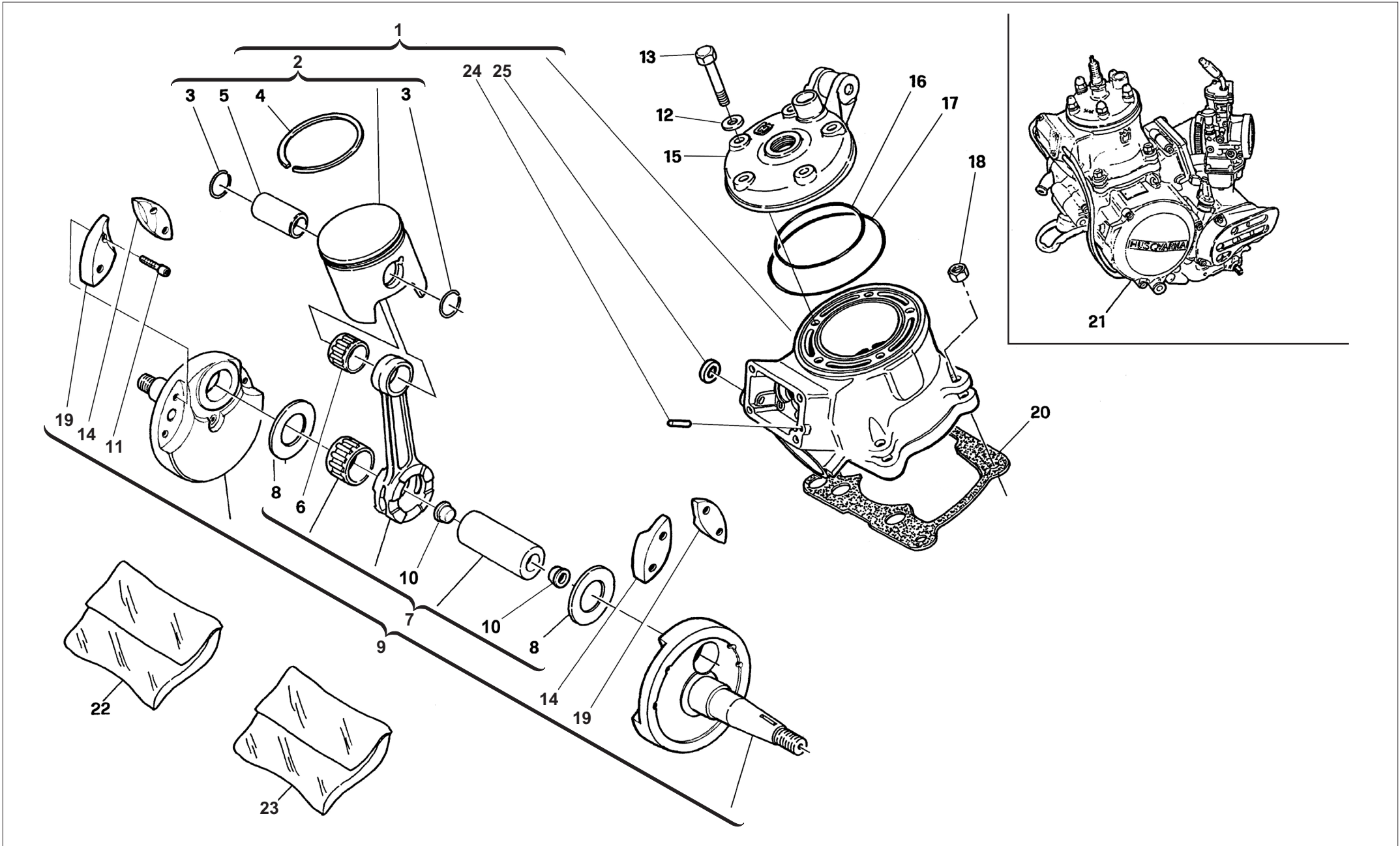

TESTA, CILINDRO, PISTONE, MANOVELLISMO - CYLINDER HEAD, CYLINDER, PISTON, CRANKSHAFT
CULASSE, CYLINDRE, PISTON, VILEBREQUIN - ZYLINDERKOPF, ZYLINDER, KOLBEN, KURBELWELLE
CULATA, CILINDRO, PISTON, PALANCAS

Note Notes Notes Marke Notas	Pos. No. N. Index Pos.	N. Cod. Code No. Nr. Code Code Nr N. Cod.	Q.tà Q.ty Q.te M.ge C.ad	DENOMINAZIONE	NAME	DESIGNATION	BESHREIBUNG	DENOMINACION
C	1	8000 H2247	1	Cilindro completo	Cylinder assy	Cylindre compl.	Zylinder kpl.	Cilindro compl.
W	1	8000 B0471	1	Cilindro completo	Cylinder assy	Cylindre compl.	Zylinder kpl.	Cilindro compl.
	2	8000 99749/1	1	Pistone completo A-B (ø 53,940÷53,950 mm)	Compl. piston A-B (ø 53,940÷53,950 mm)	Piston complet A-B (ø 53,940÷53,950 mm)	Kolben, kpl. A-B (ø 53,940÷53,950 mm)	Pistón completo A-B (ø 53,940÷53,950 mm)
	2	8000 99749/2	1	Pistone completo C-D (ø 53,950÷53,960 mm)	Compl. piston C-D (ø 53,950÷53,960 mm)	Piston complet C-D (ø 53,950÷53,960 mm)	Kolben, kpl. C-D (ø 53,950÷53,960 mm)	Pistón completo C-D (ø 53,950÷53,960 mm)
	2	8000 99749/3	1	Pistone completo E-F (ø 53,960÷53,970 mm)	Compl. piston E-F (ø 53,960÷53,970 mm)	Piston complet E-F (ø 53,960÷53,970 mm)	Kolben, kpl. E-F (ø 53,960÷53,970 mm)	Pistón completo E-F (ø 53,960÷53,970 mm)
	3	8000 10314	2	Anellino ritegno spinotto	Circlip	Bague d'arret	Federring	Anillo de retención
	4	8000 A4506	1	Segmento	Circlip	Segment	Kolbenring	Segmento
	5	8000 83066	1	Spinotto	Gudgeon	Axe	Bolzen	Perno
	6	8000 83071	1	Cuscinetto a rullini	Needle bearing	Roulement à aiguilles	Nadelkäfig	Cojinete
	7	8000 88810	1	Biella motore compl.	Connecting rod compl.	Bielle compl.	Pleuelstange kpl.	Biela motor completa
	8	8000 50629	2	Rosetta	Washer	Rondelle	Scheibe	Arandela
	9	8000 A8443	1	Compl. albero motore	Crankshaft assy	Vilebrequin compl.	Kurbewelle kpl.	Cigüeñal compl.
	10	8000 57196	2	Tappo	Plug	Bouchon	Verschluss	Tapón
	11	60N1 02486	8	Vite	Screw	Vis	Schraube	Tornillo
	12	8000 39335	5	Rosetta	Washer	Rondelle	Scheibe	Arandela
	13	ZK00 69056	5	Vite flangiata	Flange bolt	Boulon de bride	Flanschschraube	Perno de reborde
	14	8000 A8447	2	Inserto	Insert	Insert	Platte	Inserto
	15	8000 83070	1	Testa cilindro	Cylinder head	Culasse cylindre	Zylinderkopf	Culada cilindro
	16	8000 39630	1	Anello OR interno	O-Ring	Bague OR	O Ring	Anillo OR
	17	8000 70635	1	Anello OR esterno	O-Ring	Bague OR	O Ring	Anillo OR
	18	80B0 43928	4	Dado	Nut	Ecrou	Mutter	Tuerca
	19	8000 A8446	2	Inserto	Insert	Insert	Platte	Inserto
	20	8000 83068	1	Guarnizione (0,3 mm)	Gasket (0,3 mm)	Garnitue (0,3 mm)	Dichtung (0,3 mm)	Junta (0,3 mm)
	20	8A00 83068	1	Guarnizione (0,4 mm)	Gasket (0,4 mm)	Garnitue (0,4 mm)	Dichtung (0,4 mm)	Junta (0,4 mm)
	20	8B00 83068	1	Guarnizione (0,5 mm)	Gasket (0,5 mm)	Garnitue (0,5 mm)	Dichtung (0,5 mm)	Junta (0,5 mm)
	20	8D00 83068	1	Guarnizione (0,8 mm)	Gasket (0,8 mm)	Garnitue (0,8 mm)	Dichtung (0,8 mm)	Junta (0,8 mm)
C	21	8000 H6840	1	Motore completo	Engine assy	Moteur compl.	Motor kpl.	Guepial compl.
W	21	8000 H3936	1	Motore completo	Engine assy	Moteur compl.	Motor kpl.	Guepial compl.
R	22	8000 A8986	1	Gruppo guarnizioni motore	Engine gasket set	Groupe garniture moteur	Dichtunggruppe Motor	Grupo juntas
R	23	8000 94852	1	Gruppo anelli di tenuta motore	Engine seal ring set	Groupe bague moteur	Dichtringgruppe Motor	Grupo anillos

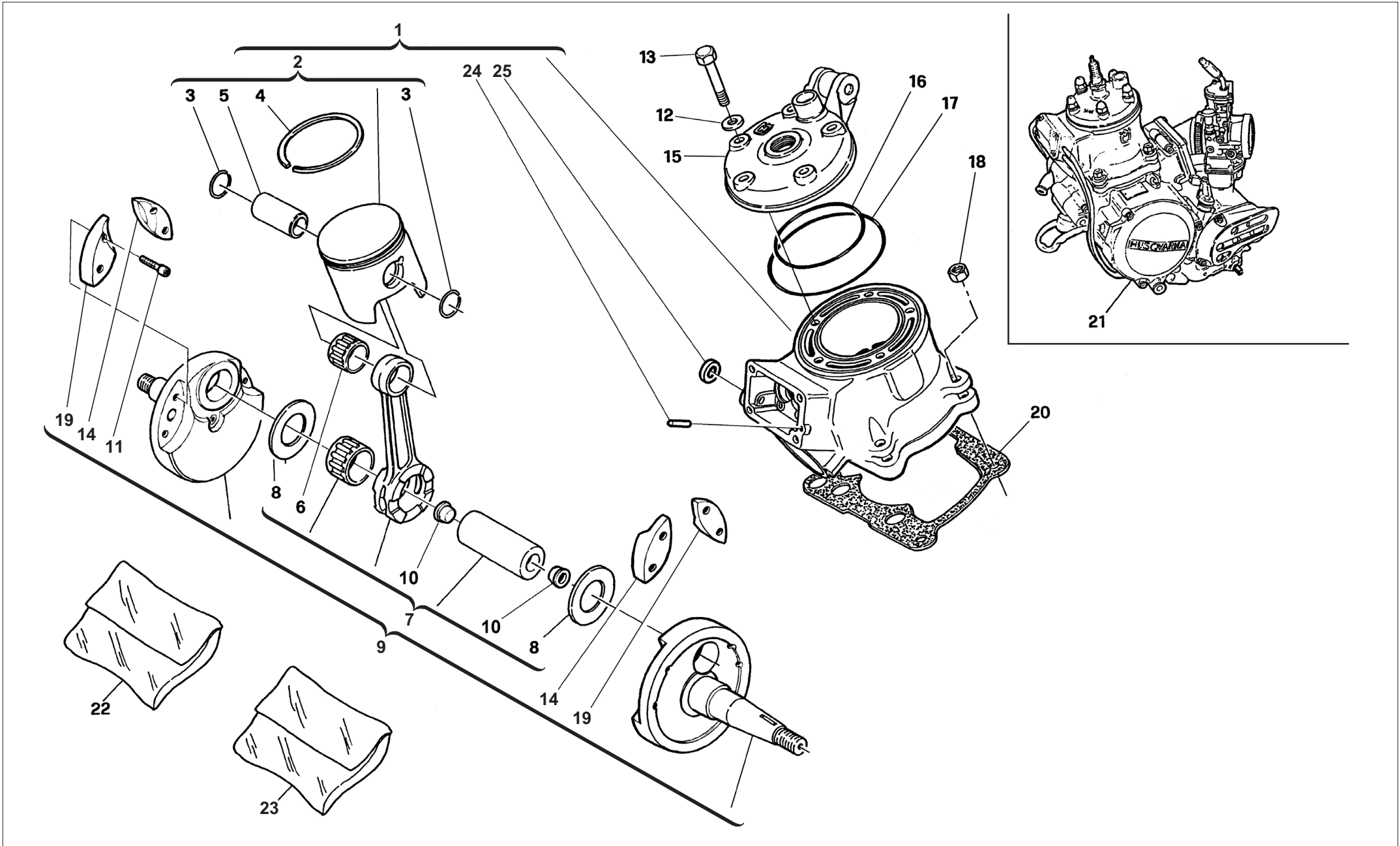

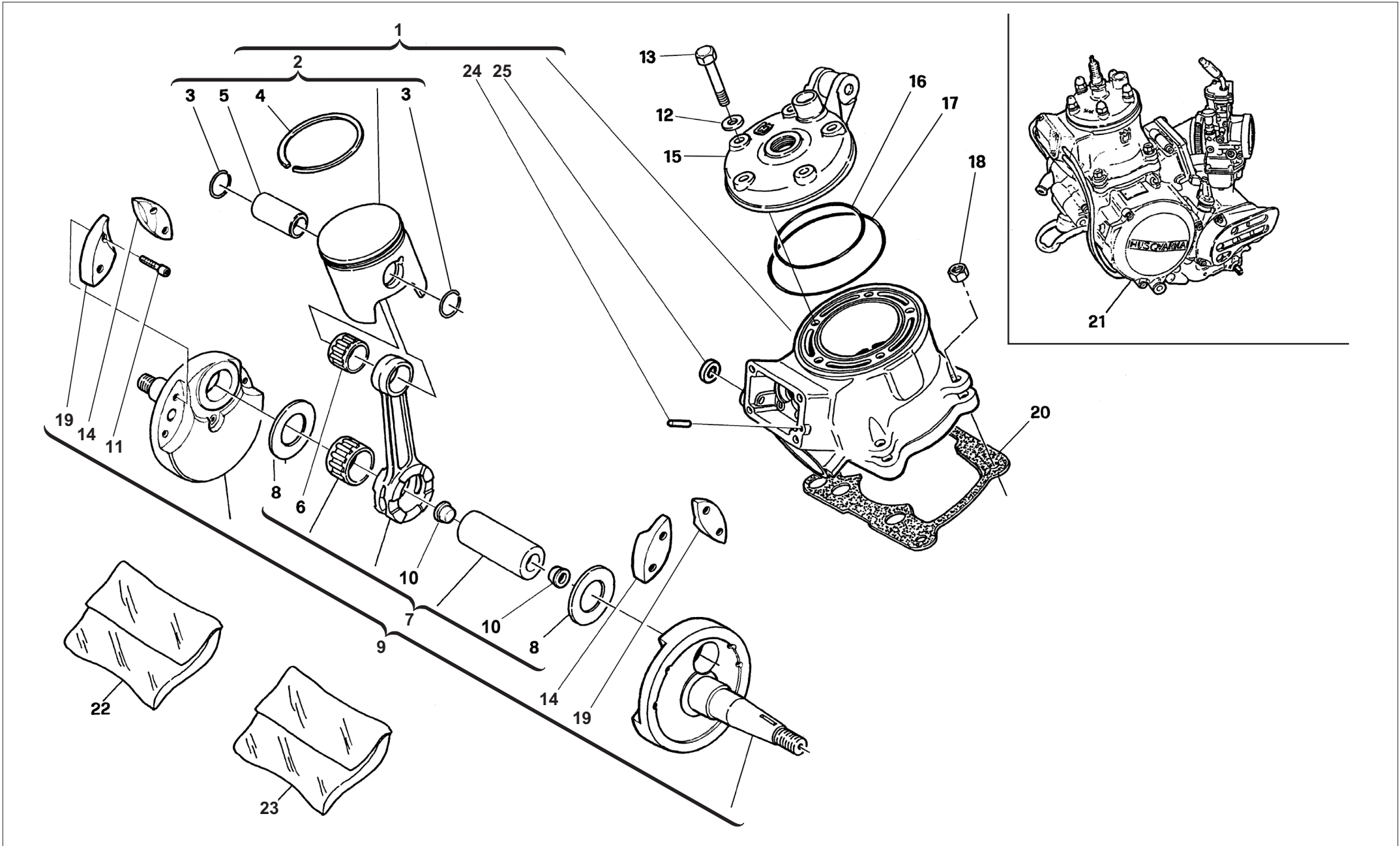

TESTA, CILINDRO, PISTONE, MANOVELLISMO - CYLINDER HEAD, CYLINDER, PISTON, CRANKSHAFT
CULASSE, CYLINDRE, PISTON, VILEBREQUIN - ZYLINDERKOPF, ZYLINDER, KOLBEN, KURBELWELLE
CULATA, CILINDRO, PISTON, PALANCAS

La sottoriportata tabella elenca i possibili accoppiamenti che consentono di ottenere il corretto gioco radiale di 0,002÷0,010 mm

The table hereunder shows the possible coupling which allow to obtain a radial clearance of 0.002÷0.010 mm

Le tableau ci-dessous indique tous les couplages possibles permettant d'obtenir le jeu radial exact de 0,002÷0,010 mm

Die folgende Tabelle gibt die möglichen Verbindungen an für das genaue Radialspiel von 0,002÷0,010 mm

La tabla que se da a continuación lista los acoplamientos posibles que permiten obtener el juego radial correcto de 0,002÷0,010 mm

C: colore di selezione biella

C: rod selection colour

C: couleur de sélection bielle

C: Wahlfarbe der Pleuelstange

C: color de selección biela

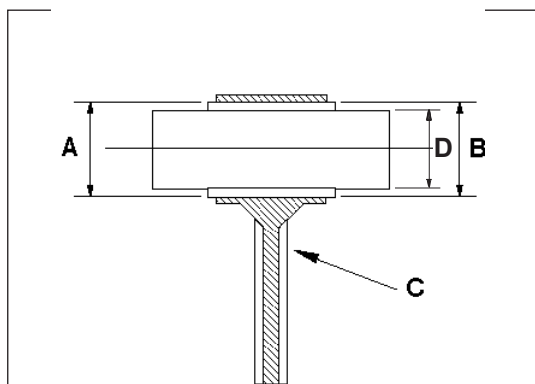

Colore di selezione foro «A» piede di biella (mm) Hole selection colour «A» connecting rod small end (mm) Couleur de sélection trou «A» pied de bielle (mm) Wahlfarbe der Bohrung «A» Pleuelstangenkopf (mm) Color de selección «A» pie de biela (mm)	Selezione gabbia a rullini «B» Cage selection «B» Sélection cage à rouleaux «B» Wahlnadelkäfig «B» Selección jaula de agujas «B»	Colore di selezione diametro «D» spinotto (mm) Diameter selection colour «D» Gudgeon (mm) Couleur de sélection diamètre «D» axe (mm) Wahlfarbe der Durchmesser «D» Bolzen (mm) Color de selección diámetro «D» perno (mm)
Rosso - Red - Rouge - Rot - Rojo 19,002 ÷ 19,004	0 ÷ - 2	Nero - Black - Noir - Schwarz - Negro 15,000 ÷ 14,998
Bianco - White - Blanc - Weiss - Blanco 18,998 ÷ 19,000	- 1 ÷ - 3	Bianco - White - Blanc - Weiss - Blanco 14,998 ÷ 14,996
Nero - Black - Noir - Schwarz - Negro 19,000 ÷ 19,002	0 ÷ - 2	Bianco - White - Blanc - Weiss - Blanco 14,998 ÷ 14,996
Nero - Black - Noir - Schwarz - Negro 19,000 ÷ 19,002	- 1 ÷ - 3	Nero - Black - Noir - Schwarz - Negro 15,000 ÷ 14,998

Qualora, in sede di revisione del motore, si dovesse riscontrare un gioco radiale superiore al limite ammesso di 0,015 mm e non fosse più visibile il contrassegno del colore sullo stelo della biella, rilevare il diametro «A» del piede di biella e, in base a questo, montare la gabbietta appropriata.

When overhauling, should a radial clearance greater than the consented limit of 0.015 mm be noticed and the colour mark under the connecting rod small end is no more visible, collect the connecting rod small end «A» diameter and assemble the right cage according to it.

Si en révisonnant le moteur on trouve un jeu radial supérieur à la limite admise de 0,015 mm et le marque de la couleur n'est plus visible sur la tige de bielle, enregistrer le diamètre «A» du pied de bielle et assembler la cage exacte selon ce diamètre.

Falls bei Motorprüfung das Radialspiel über das zugelassene Mass von 0,015 mm sein sollte und das Farbkennzeichen an der Pleuelstange nicht mehr sichtbar ist, wird der «A»-Durchmesser des Pleuelstangenkopfes gemessen und aufgrund dessen der geeignete Käfig montiert..

En el caso que, cuando inspeccione el motor, encuentre un juego radial superior al límite admitido de 0,015 mm y no resultara más visible la señalización del color en el vástago de la biela, registre el diámetro «A» del piede biela y, sobre la base de este dato, monte la jaula adecuada.

NOTA: Nel richiedere la gabbia a rullini, specificare la selezione.

NOTE: When requesting the cage, specify the selection.

NOTA: En demandant la cage à rouleaux, spécifier la sélection.

BEMERKUNG: Bei Anfrage den genauen Wahlnadelkäfig angeben.

NOTA: cuando pida la jaula de agujas, especifique la selección.

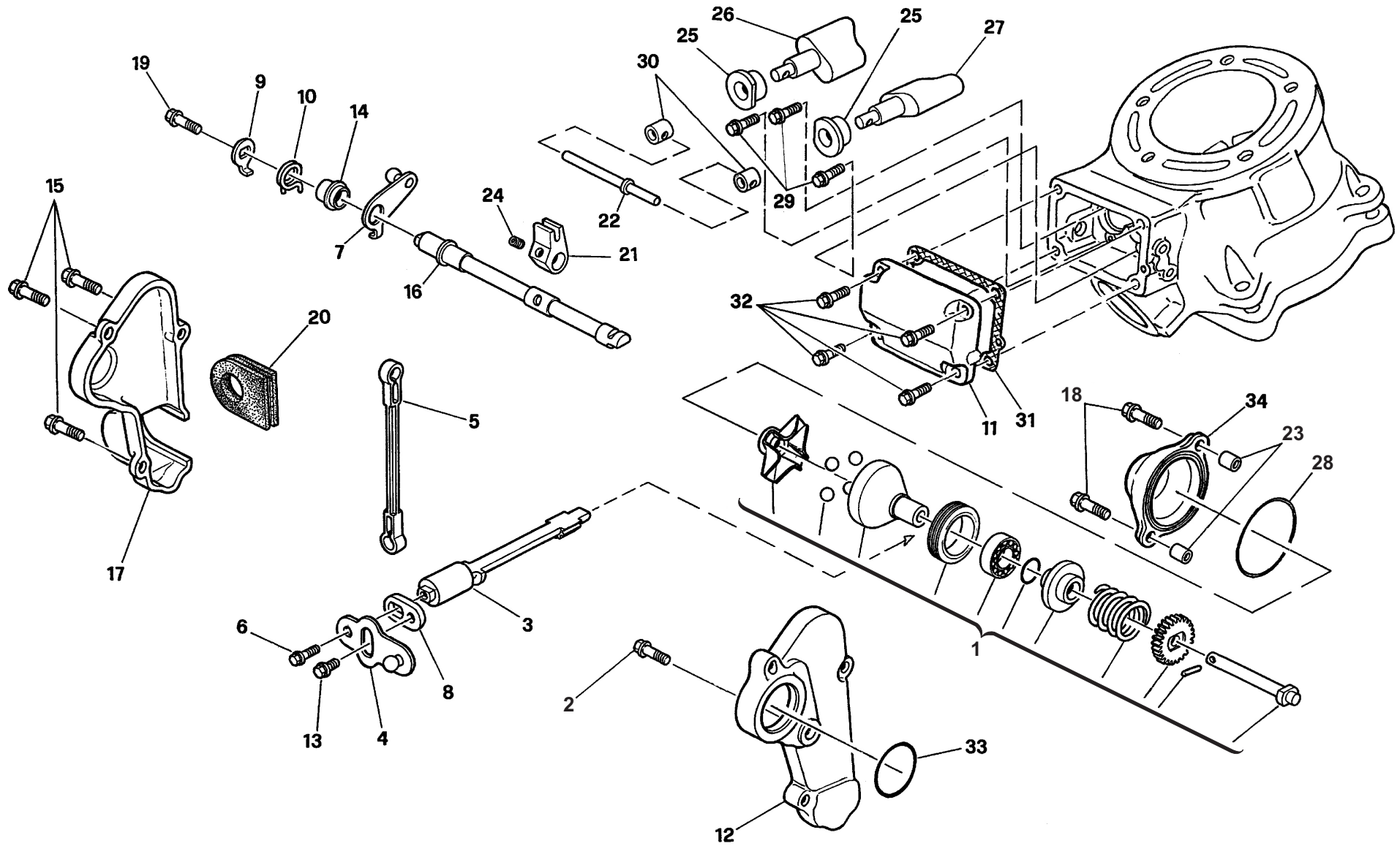

Note Notes Notes Marke Notas	Pos. No. N. Index Pos.	N. Cod. Code No. Nr. Code Code Nr N. Cod.	Q.tà Q.ty Q.te M.ge C.ad	DENOMINAZIONE	NAME	DESIGNATION	BESHREIBUNG	DENOMINACION
	1	8000 99753	1	Assieme regolatore centrifugo	Regulator assy	Reglage	Regler	Regulador
	2	8000 67997	1	Vite	Screw	Vis	Schraube	Tornillo
	3	8000 83107	1	Alberino	Shaft	Arbre	Welle	Eje
	4	8B00 57022	1	Assieme leva registro rinvio	Lever	Levier	Hebel	Palanca
	5	8000 83115	1	Astina	Rod	Tige	Stange	Varilla
	6	Z000 67997	1	Vite	Screw	Vis	Schraube	Tornillo
	7	8000 B1359	1	Assieme leva	Lever	Levier	Hebel	Palanca
	8	8A00 57024	1	Leva rinvio	Lever	Levier	Hebel	Palanca
	9	8000 83110	1	Leva	Lever	Levier	Hebel	Palanca
	10	8000 83109	1	Molla	Spring	Ressort	Feder	Resorte
	11	8000 83090	1	Coperchio	Cover	Couvercle	Deckel	Tapa
	12	80A0 H2265	1	Basetta	Side	Base	Platte	Placa
	13	ZF00 67997	1	Vite	Screw	Vis	Schraube	Tornillo
	14	8000 83114	1	Mozzo	Hub	Moyeau	Radnabe	Cubo
	15	8A00 67997	3	Vite	Screw	Vis	Schraube	Tornillo
	16	8000 83116	1	Albero comando valvole	Valve shaft	Arbre de comande soupape	Ventilwelle	Eje mando valvula
	17	80A0 H0168	1	Coperchio	Cover	Couvercle	Deckel	Tapa
	18	8000 62729	2	Vite	Screw	Vis	Schraube	Tornillo
	19	Z000 67997	1	Vite	Screw	Vis	Schraube	Tornillo
	20	8000 83092	1	Guarnizione	Gasket	Garniture	Dichtung	Junta
	21	8000 83119	1	Biscottino leva	Lever	Levier	Hbel	Palanca
	22	8000 83113	1	Perno di trascinamento	Pin	Pivot	Bolzen	Perno
	23	1617 95501	2	Bussola	Bushing	Douille	Buchse	Buje
	24	8000 83121	1	Grano	Dowel	Grain	Stift	Pasadòr
	25	8000 83118	2	Bussola ritegno valvole	Valve retaining bush	Douille	Buchse	Buje
C	26	8000 B0475	1	Valvola di scarico Dx	R.H. exhaust valve	Soupape diechappement D.	Auslassventil R.	Válvula de escape der.
W	26	8000 H2040	1	Valvola di scarico Dx	R.H. exhaust valve	Soupape diechappement D.	Auslassventil R.	Válvula de escape der.
C	27	8000 B0476	1	Valvola di scarico Sx	L.H. exhaust valve	Soupape diechappement G.	Auslassventil L.	Válvula de escape izq.
W	27	8000 H2039	1	Valvola di scarico Sx	L.H. exhaust valve	Soupape diechappement G.	Auslassventil L.	Válvula de escape izq.
	28	8000 28553	1	Anello di tenuta	Seal ring	Bague d'etancheite	Dichtring	Anillo de retención
	29	ZE00 67997	3	Vite	Screw	Vis	Schraube	Tornillo
	30	8000 A3557	2	Fermo corsa	Retainer	Arret	Klammer	Abrazaderza
	31	8000 83049	1	Guarnizione	Gasket	Garniture	Dichtung	Junta

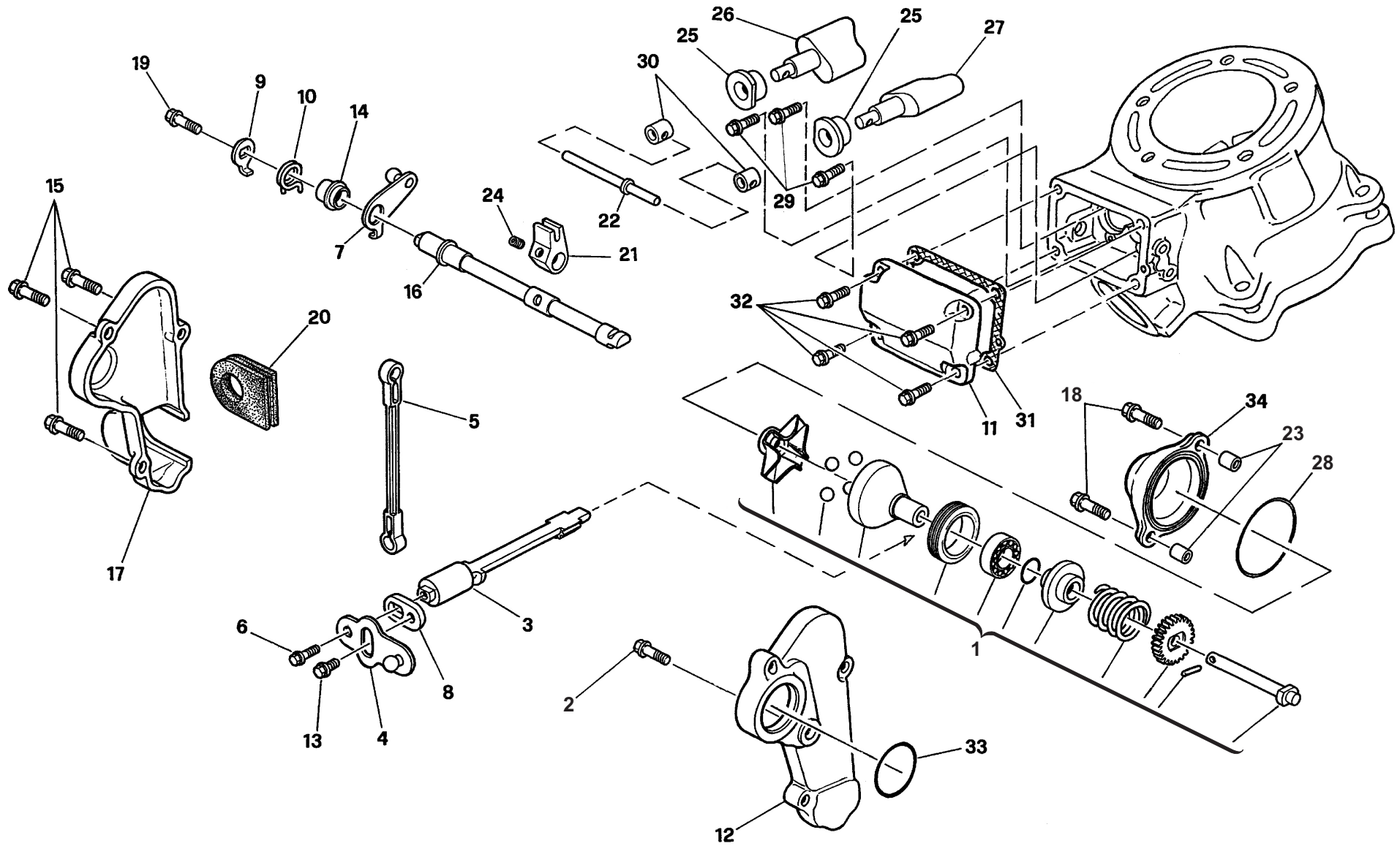



TAVOLA 20
DRAWING 20
TABLE 20
BILD 20
TABLA 20

RAFFREDDAMENTO - COOLING SYSTEM
REFROIDISSEMENT - WASSERKÜHLUNG
ENFRIAMIENTO
TAVOLA - DRAWING
TABLE - BILD - TABLA

4

Note Notes Notes Marke Notas	Pos. No. N. Index Pos.	N. Cod. Code No. Nr. Code Code Nr N. Cod.	Q.tà Q.ty Q.te M.ge C.ad	DENOMINAZIONE	NAME	DESIGNATION	BESHREIBUNG	DENOMINACION
	1	8000 79561	1	Alberino com. pompa acqua	Shaft	Arbre	Welle	Eje
	2	8AA0 A0872	2	Griglia	Grid	Grille	Rost	Parilla
	3	8000 A7971	1	Radiatore sinistro (KTM)	Left radiator (KTM)	Radiateur gauche (KTM)	Linker Kühler (KTM)	Radiador izquierdo (KTM)
	4	8000 65935	1	Ingranaggio pompa	Pinion	Pignon	Ritzel	Engranaje
	5	8E00 34292	1	Rosetta	Washer	Rondelle	Scheibe	Arandela
	6	8F00 28960	1	Rosetta	Washer	Rondelle	Scheibe	Arandela
	7	8000 68277	1	Girante	Impeller	Propulseur	Fluelgelrad	Turbina impuls
	8	80B0 83024	1	Corpo pompa	Pump body	Corps pompe	Pumpenkörper	Corpo bomba
	9	8000 65922	1	Guarnizione	Gasket	Garniture	Dichtung	Junta
	10	1617 95501	2	Bussola	Bushing	Douille	Buchse	Buje
	11	8000 62731	1	Vite (M6x45 mm)	Screw (M6x45 mm)	Vis (M6x45 mm)	Schraube (M6x45 mm)	Tornillo (M6x45 mm)
	12	ZB00 67545	1	Vite	Screw	Vis	Schraube	Tornillo
	13	Z000 62728	1	Vite	Screw	Vis	Schraube	Tornillo
	14	ZS00 67545	1	Vite	Screw	Vis	Schraube	Tornillo
	15	8000 03271	1	Rosetta	Washer	Rondelle	Scheibe	Arandela
	16	8000 88894	1	Tubazione	Pipe	Tuyau	Rohr	Tubo
	17	8B00 99475	1	Fascetta	Clamp	Collier	Schelle	Banda
	18	Z000 62729	4	Vite (M6x25 mm)	Screw (M6x25 mm)	Vis (M6x25 mm)	Schraube (M6x25 mm)	Tornillo (M6x25 mm)
	19	8000 93181	1	Tubo	Pipe	Tuyau	Rohr	Tubo
	20	8000 H2168	4	Dado a graffetta	Nut	Ecrou	Mutter	Tuerca
	21	8A00 99475	4	Fascetta	Clamp	Collier	Schelle	Banda
	22	8000 56462	2	Fascetta	Clamp	Collier	Schelle	Banda
	23	9472 00019	1	Tubazione (L=110 mm)	Pipe (L=110 mm)	Tuyau (L=110 mm)	Rohr (L=110 mm)	Tubo (L=110 mm)
A	24	8000 A7970	1	Radiatore destro (KTM)	Right radiator (KTM)	Radiateur droit (KTM)	Rechter Kühler (KTM)	Radiador derecho (KTM)
A	25	8000 A7972	1	Tappo radiatore (KTM)	Plug (KTM)	Bouchon (KTM)	Verschluss (KTM)	Tapón (KTM)
	26	8000 59803	6	Gommino	Rubber pad	Pièce caoutchouc	Gummistück	Junta de goma
	27	8D00 59802	6	Bussola	Bushing	Douille	Buchse	Buje
	28	Z000 59801	6	Rosetta	Washer	Rondelle	Scheibe	Arandela
	29	8B00 43715	1	Tubetto sfiato	Tube	Tuyau	Rohr	Tubo

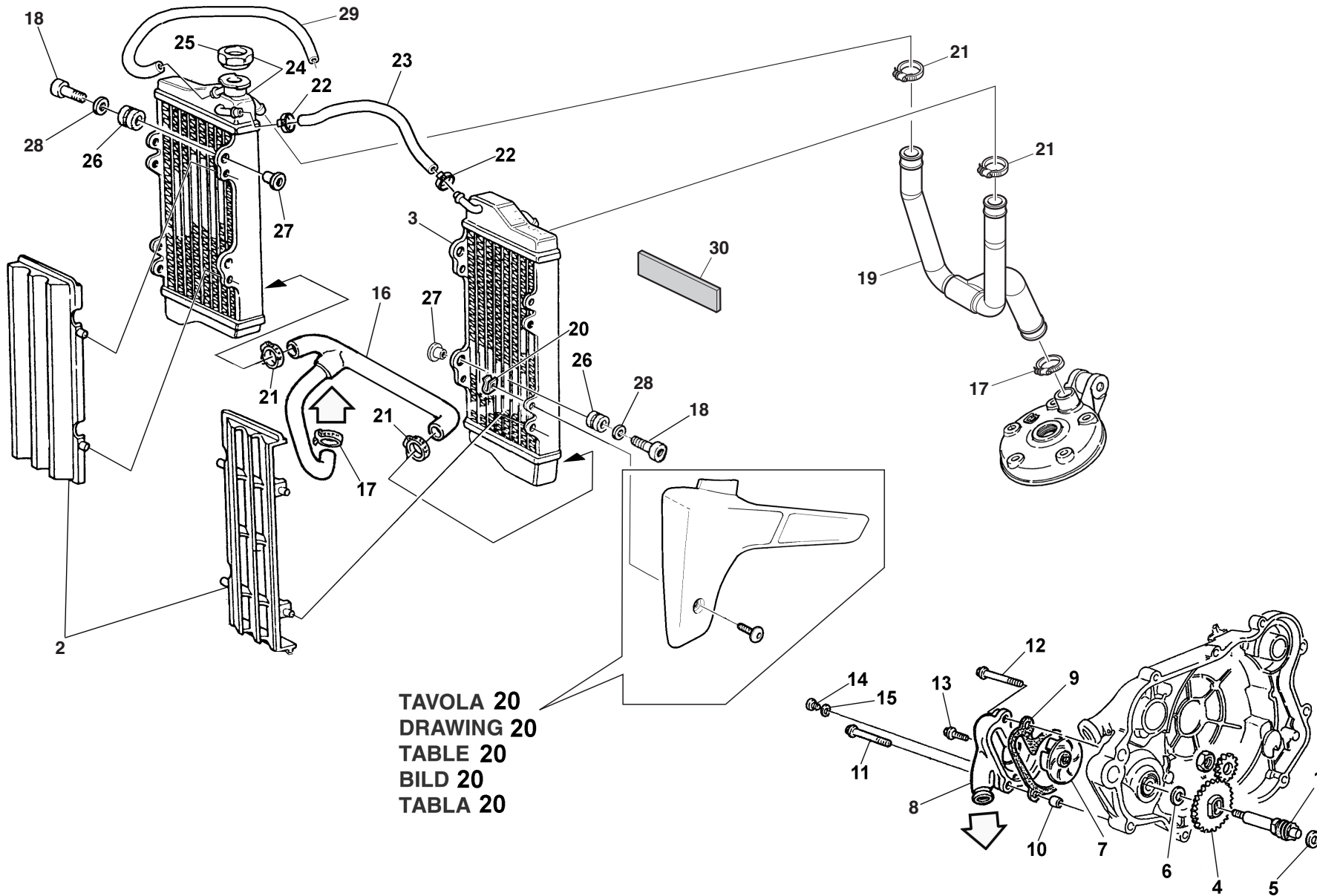

TAVOLA 20
DRAWING 20
TABLE 20
BILD 20
TABLA 20



RAFFREDDAMENTO - COOLING SYSTEM
REFROIDISSEMENT - WASSERKÜHLUNG
ENFRIAMIENTO
TAVOLA - DRAWING
TABLE - BILD - TABLA**4A**

Note Notes Notes Marke Notas	Pos. No. N. Index Pos.	N. Cod. Code No. Nr. Code Code Nr N. Cod.	Q.tà Q.ty Q.te M.ge C.ad	DENOMINAZIONE	NAME	DESIGNATION	BESHREIBUNG	DENOMINACION
	1	8000 79561	1	Alberino com. pompa acqua	Shaft	Arbre	Welle	Eje
	2	8000 94680	1	Boccola	Bushing	Douille	Buchse	Buje
	3	9472 00006	1	Tubo	Pipe	Tuyau	Rohr	Tubo
	4	8000 65935	1	Ingranaggio pompa	Pinion	Pignon	Ritzel	Engranaje
	5	8E00 34292	1	Rosetta	Washer	Rondelle	Scheibe	Arandela
	6	8F00 28960	1	Rosetta	Washer	Rondelle	Scheibe	Arandela
	7	8000 68277	1	Girante	Impeller	Propulseur	Fluegelrad	Turbina impuls
	8	80B0 83024	1	Corpo pompa	Pump body	Corps pompe	Pumpenkörper	Corpo bomba
	9	8000 65922	1	Guarnizione	Gasket	Garniture	Dichtung	Junta
	10	1617 95501	2	Bussola	Bushing	Douille	Buchse	Buje
	11	8000 62731	1	Vite (M6x45 mm)	Screw (M6x45 mm)	Vis (M6x45 mm)	Schraube (M6x45 mm)	Tornillo (M6x45 mm)
	12	ZB00 67545	1	Vite	Screw	Vis	Schraube	Tornillo
	13	Z000 62728	1	Vite	Screw	Vis	Schraube	Tornillo
	14	ZS00 67545	1	Vite	Screw	Vis	Schraube	Tornillo
	15	8000 03271	1	Rosetta	Washer	Rondelle	Scheibe	Arandela
	16	8000 95640	1	Tubazione	Pipe	Tuyau	Rohr	Tubo
	17	8B00 99475	4	Fascetta	Clamp	Collier	Schelle	Banda
	18	8000 99475	3	Fascetta	Clamp	Collier	Schelle	Banda
	19	8000 94681	1	Tubo termostato-radiatori	Pipe	Tuyau	Rohr	Tubo
	20	8000 H2168	4	Dado a graffetta	Nut	Ecrou	Mutter	Tuerca
	21	8A00 99475	4	Fascetta	Clamp	Collier	Schelle	Banda
	22	8000 56462	2	Fascetta	Clamp	Collier	Schelle	Banda
	23	9472 00019	1	Tubazione (L=110 mm)	Pipe (L=110 mm)	Tuyau (L=110 mm)	Rohr (L=110 mm)	Tubo (L=110 mm)
	24	8000 A7970	1	Radiatore destro (KTM)	Right radiator (KTM)	Radiateur droit (KTM)	Rechter Kühler (KTM)	Radiador derecho (KTM)
	25	8000 A7972	1	Tappo radiatore (KTM)	Plug (KTM)	Bouchon (KTM)	Verschluss (KTM)	Tapón (KTM)
	26	8000 59803	6	Gommino	Rubber pad	Pièce caoutchouc	Gummistück	Junta de goma
	27	8D00 59802	6	Bussola	Bushing	Douille	Buchse	Buje
	28	Z000 62729	4	Vite (M6x22 mm)	Screw (M6x22 mm)	Vis (M6x22 mm)	Schraube (M6x22 mm)	Tornillo (M6x22 mm)
	29	8B00 43715	1	Tubetto sfiato	Tube	Tuyau	Rohr	Tubo
	30	8000 37140	1	Antivibrante	Silent-block	Antivibration	Schwingungsdämpfer	Anti-vibrador
	31	8000 A7971	1	Radiatore sinistro (KTM)	Left radiator (KTM)	Radiateur gauche (KTM)	Linker Kühler (KTM)	Radiador izquierdo (KTM)
	32	8000 75984	1	Termostato	Thermostat	Thermostat	Thermostat	Termostato
	33	8AA0 A0872	2	Griglia	Grid	Grille	Rost	Parilla

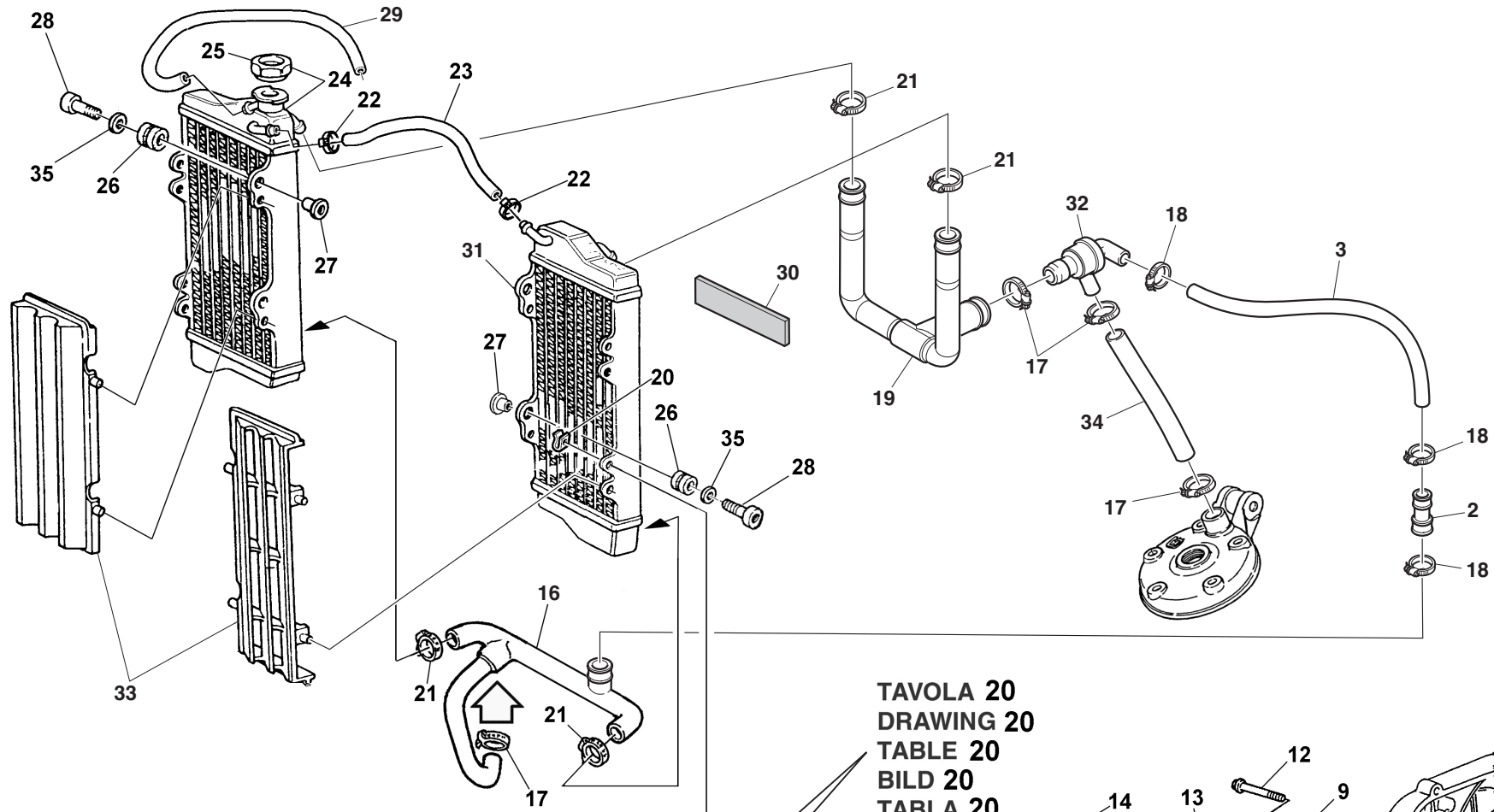
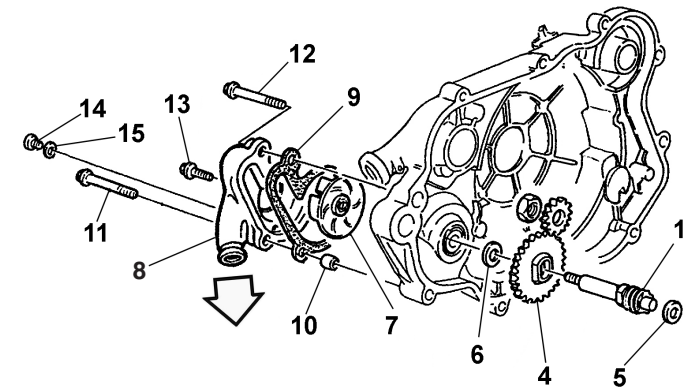

TAVOLA 20
DRAWING 20
TABLE 20
BILD 20
TABLA 20



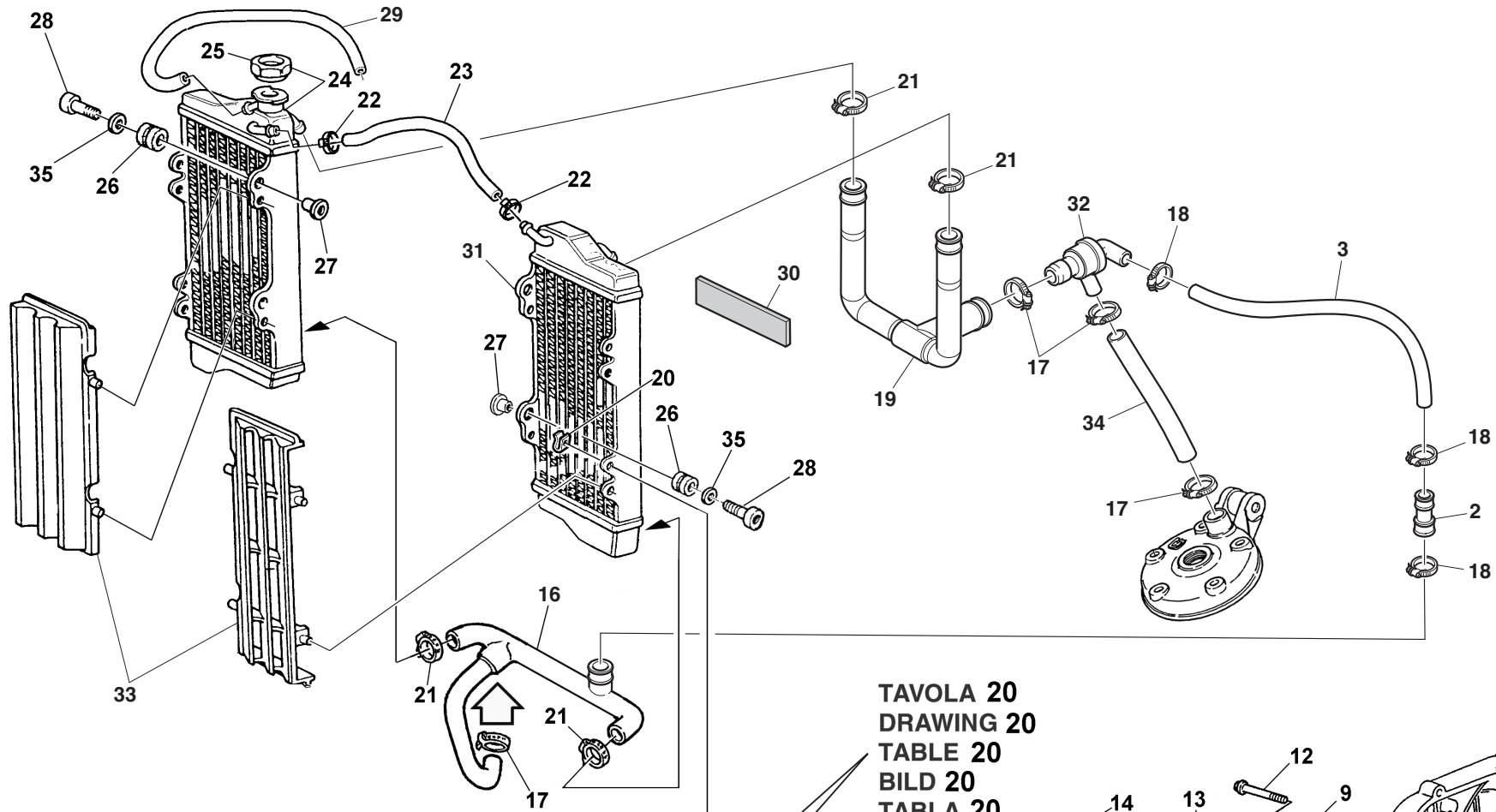
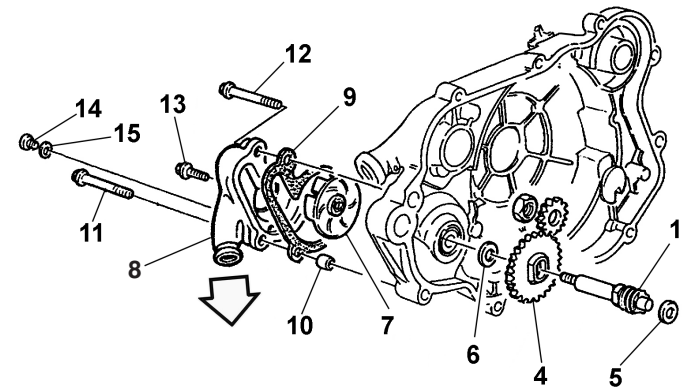
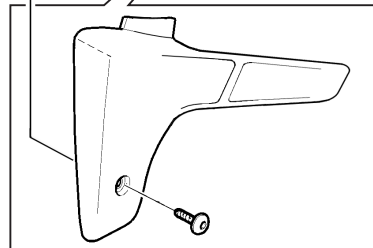
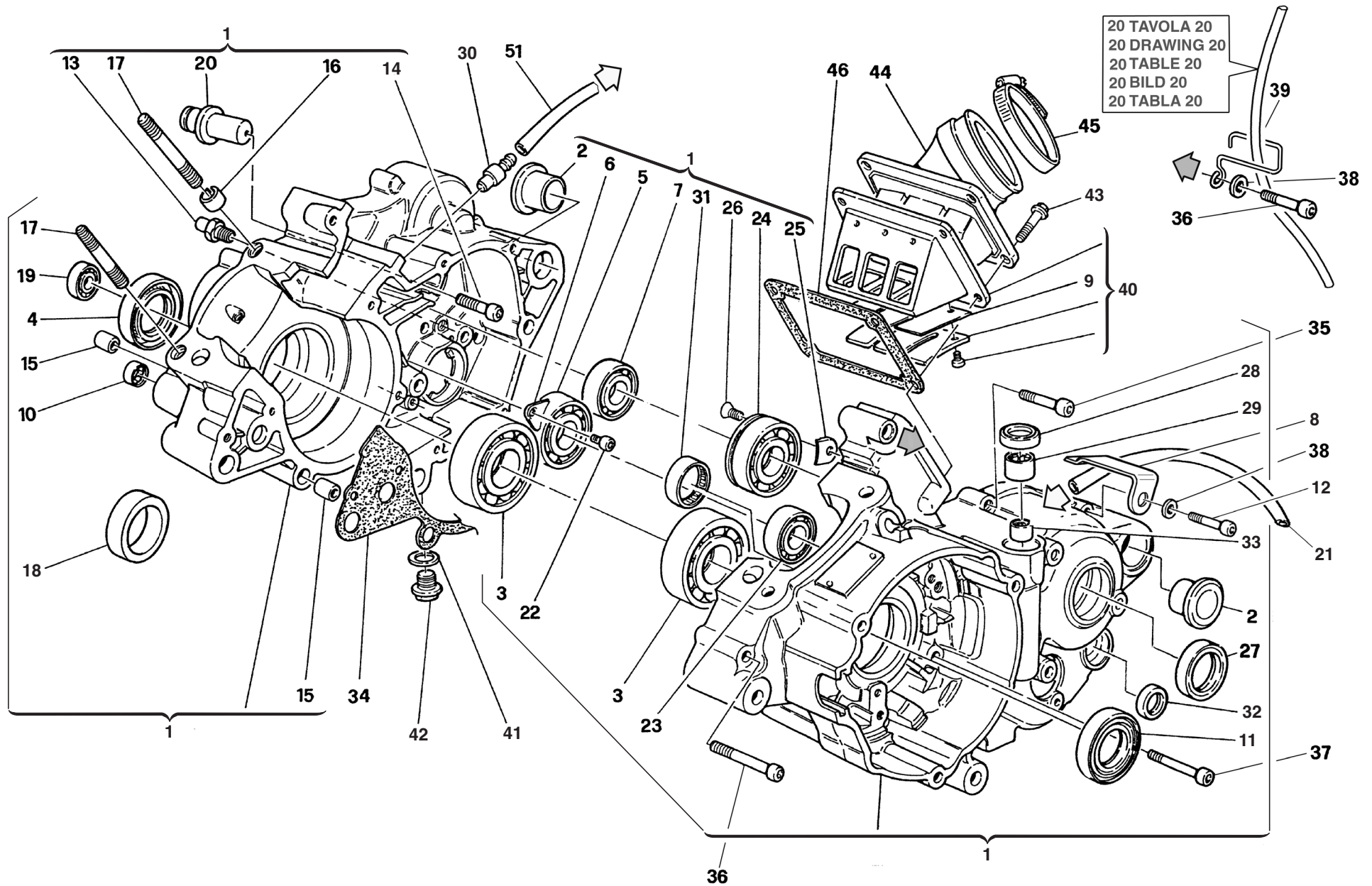

BASAMENTO - CRANKCASE - CARTER - GEHAUSE - BANCADA

Note Notes Notes Marke Notas	Pos. No. N. Index Pos.	N. Cod. Code No. Nr. Code Code Nr N. Cod.	Q.tà Q.ty Q.te M.ge C.ad	DENOMINAZIONE	NAME	DESIGNATION	BESHREIBUNG	DENOMINACION
	1	W000 W0621	1	Carter accoppiati compl.	Crankcase assy	Carters assemblé compl.	Kürbelgehäuse kpl.	Carter motor compl.
	2	8A00 71154	2	Bussola	Bushing	Douille	Buchse	Buje
	3	8000 88828	2	Cuscinetto	Bearing	Roulement	Kugellager	Cojinete
	4	8000 59977	1	Anello di tenuta	Seal ring	Bague d'etancheite	Dichtring	Anillo de retención
	5	8000 43382	1	Cuscinetto	Bearing	Roulement	Kugellager	Cojinete
	6	8000 53324	1	Piastrina	Plate	Plaque	Platte	Placa
	7	8000 21939	1	Cuscinetto	Bearing	Roulement	Kugellager	Cojinete
	8	Z000 H0643	1	Piastra fiss. tubi sfiato carburatore	Pipe retain plate	Plaquette	Platte	Plaquita
	9	8000 H0477	2	Lamella	Plate	Plaquette	Plättchen	Placa
	10	8000 47678	1	Cuscinetto a rullini	Needle bearing	Roulement à aiguilles	Nadelkäfig	Cojinete
	11	8000 92896	1	Anello di tenuta	Seal ring	Bague d'etancheite	Dichtring	Anillo de retención
	12	60ND 02518	2	Vite	Screw	Vis	Schraube	Tornillo
	13	8A00 66953	1	Perno di fermo selettore	Pin	Pivot	Bolzen	Perno
	14	60ND 07335	1	Vite (M6x16 mm)	Screw (M6x16 mm)	Vis (M6x16 mm)	Schraube (M6x16 mm)	Tornillo (M6x16 mm)
	15	8000 07719	4	Bussola	Bushing	Douille	Buchse	Buje
	16	8000 99767	1	Spina elastica	Pin	Goupille	Stift	Clavija
	17	8000 74836	4	Prigioniero	Stud bolt	Prisonnier	Stiftschraube	Prisionero
	18	8000 74082	1	Tappo	Plug	Bouchon	Verschluss	Tapón
	19	8000 06597	1	Cuscinetto	Bearing	Roulement	Kugellager	Cojinete
	20	8000 77841	1	Perno	Pin	Pivot	Bolzen	Perno
	21	8000 41750	1	Tubetto sfiato	Tube	Tuyau	Rohr	Tubo
	22	8000 67997	1	Vite (M5x12 mm)	Screw (M5x12 mm)	Vis (M5x12 mm)	Schraube (M5x12 mm)	Tornillo (M5x12 mm)
	23	8000 21939	1	Cuscinetto	Bearing	Roulement	Kugellager	Cojinete
	24	8000 51745	1	Cuscinetto	Bearing	Roulement	Kugellager	Cojinete
	25	8000 51746	1	Piastrina	Plate	Plaque	Platte	Placa
	26	Z000 42643	1	Vite	Screw	Vis	Schraube	Tornillo
	27	8000 36357	1	Anello di tenuta	Seal ring	Bague d'etancheite	Dichtring	Anillo de retención
	28	8000 48856	1	Anello di tenuta	Seal ring	Bague d'etancheite	Dichtring	Anillo de retención
	29	8000 49016	1	Boccola (ø13xø19x12 mm)	Bushing (ø13xø19x12 mm)	Douille (ø13xø19x12 mm)	Buchse (ø13xø19x12 mm)	Buje (ø13xø19x12 mm)
	30	8000 76262	1	Raccordo sfiato	Union	Raccord	Anschluss	Empalme
	31	8000 62200	1	Cuscinetto a rullini	Needle bearing	Roulement à aiguilles	Nadelkäfig	Cojinete
	32	8000 34451	1	Anello di tenuta	Seal ring	Bague d'etancheite	Dichtring	Anillo de retención
	33	8000 47678	1	Cuscinetto a rullini	Needle bearing	Roulement à aiguilles	Nadelkäfig	Cojinete

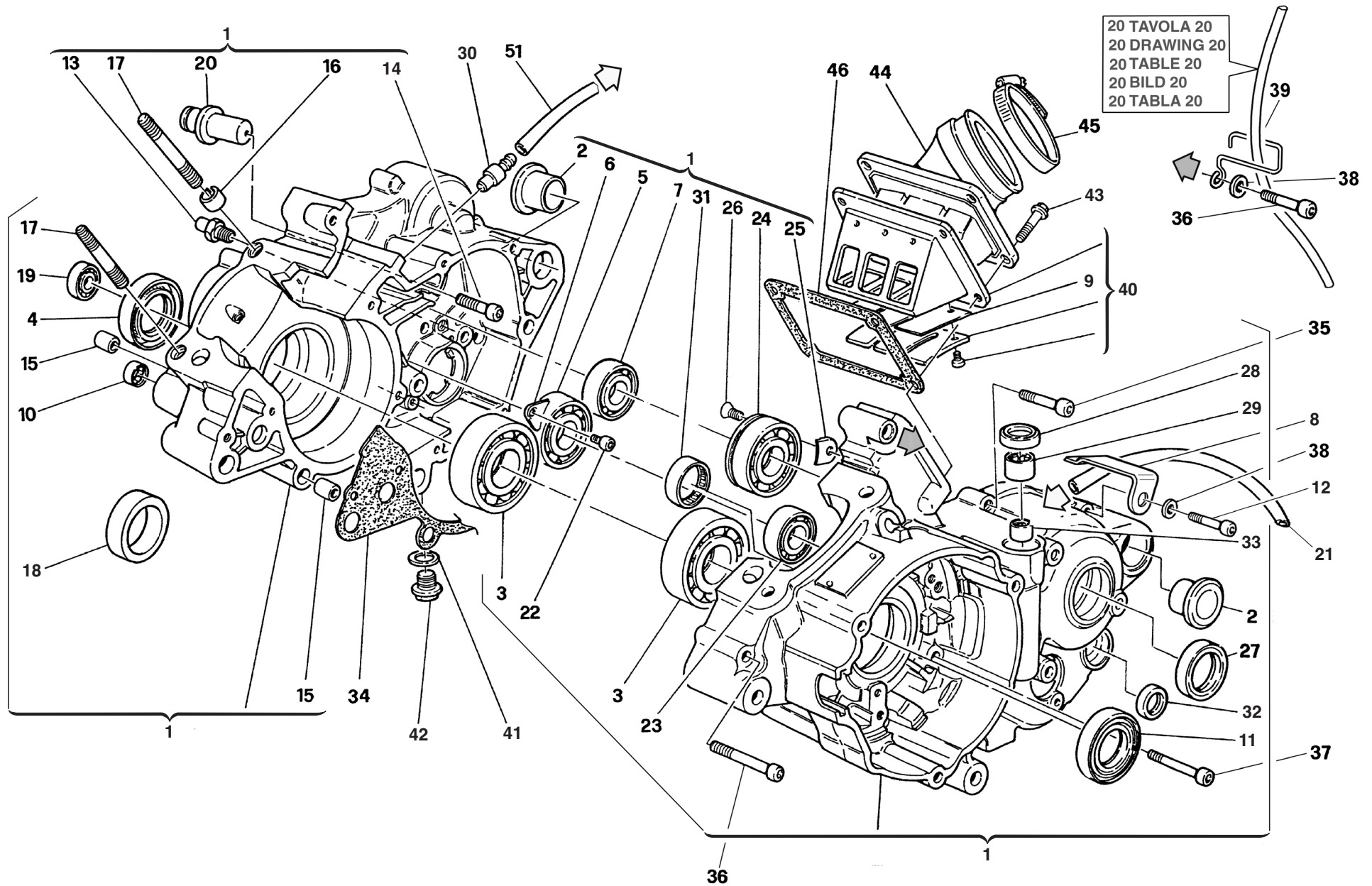

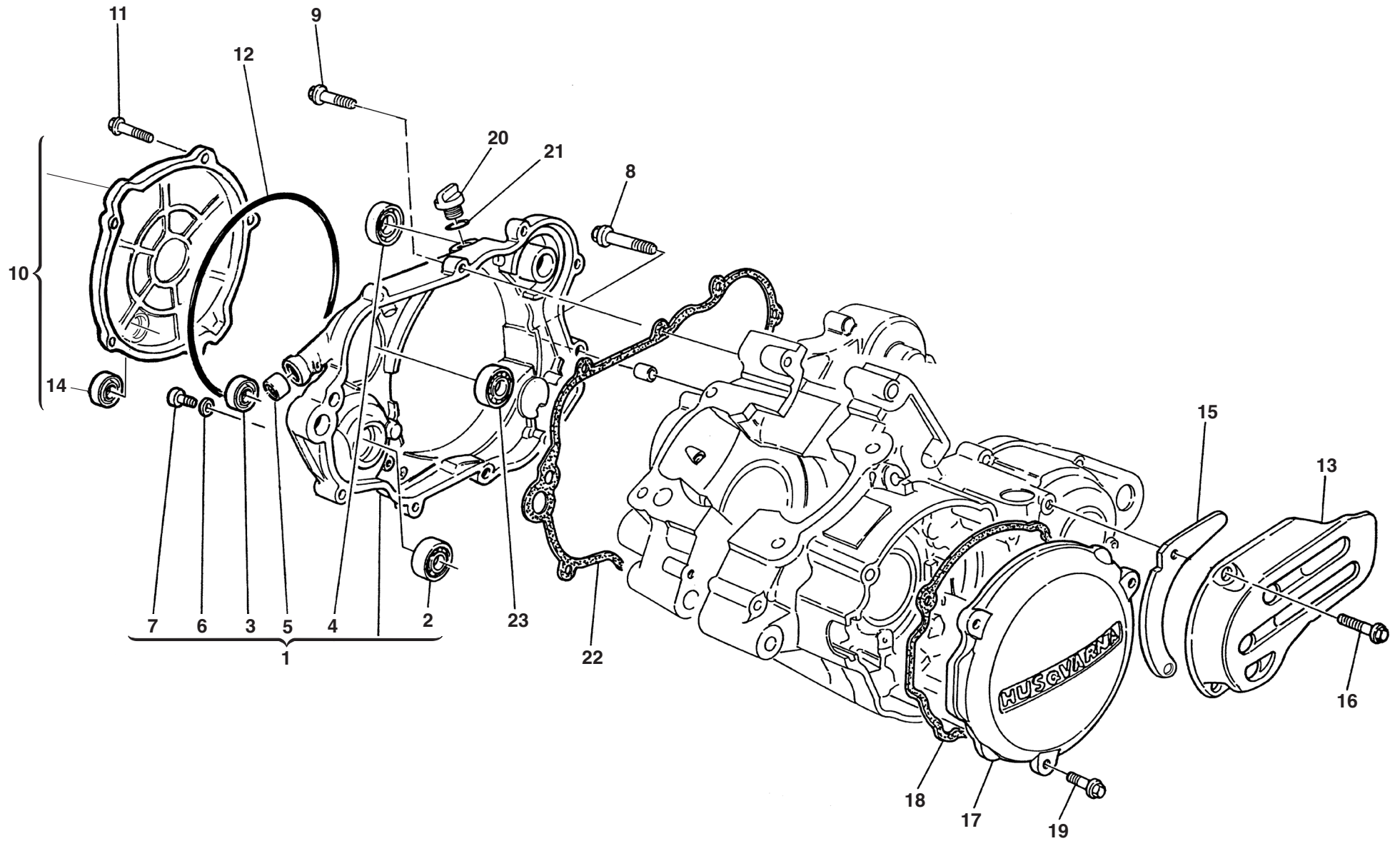

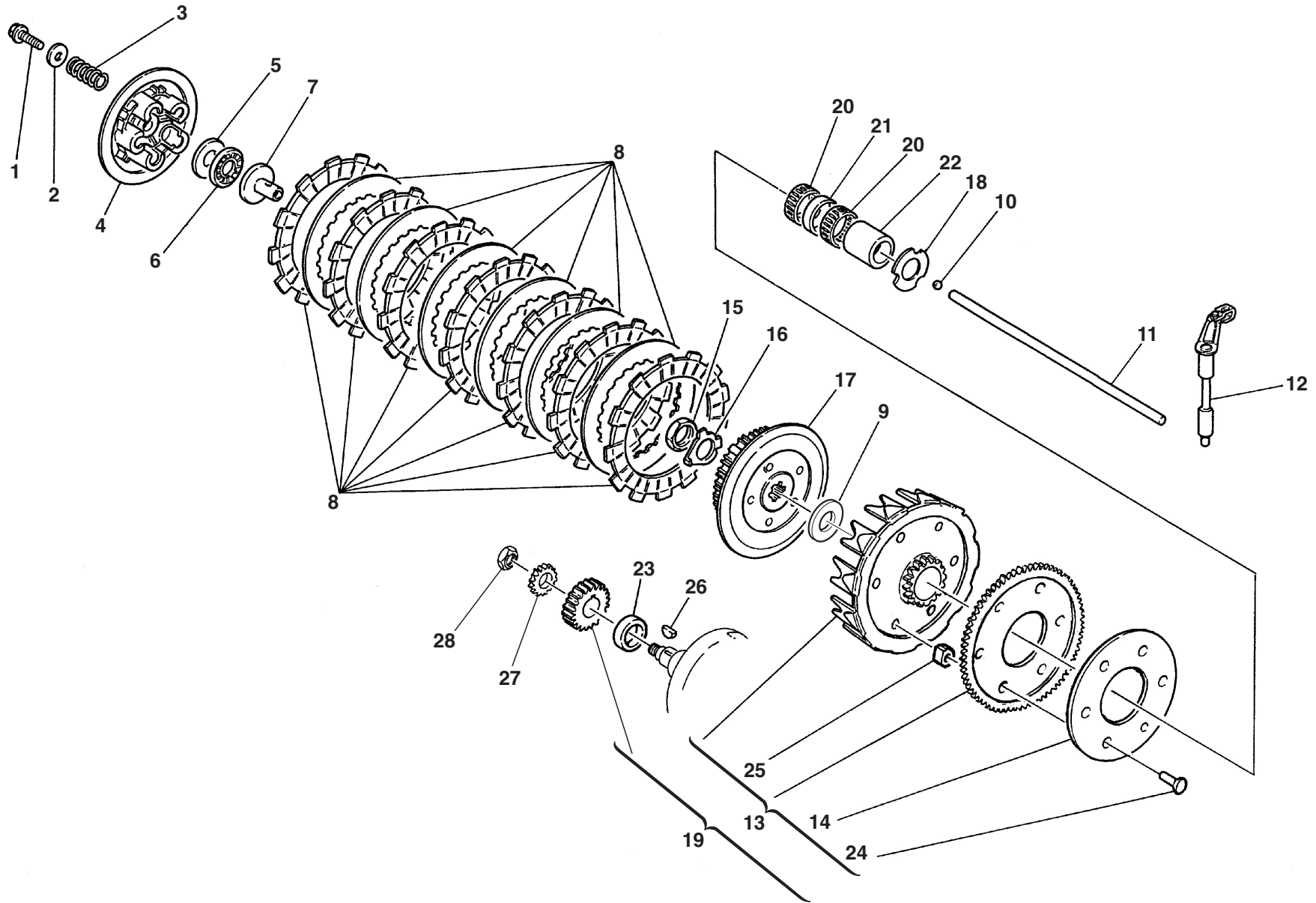

**FRIZIONE, TRASMISSIONE PRIMARIA - CLUTCH, PRIMARY DRIVE
EMBRAYAGE, TRANSMISSION PRIMARIE - KUPPLUNG, ERSTERANTRIEB
ENBRAGUE, TRANSMISION PRIMARIA**



Note Notes Marke Notas	Pos. No. Index Pos.	N. Cod. Code No. Nr. Code Code Nr N. Cod.	Q.tà Q.ty Q.te M.ge C.ad	DENOMINAZIONE	NAME	DESIGNATION	BESHREIBUNG	DENOMINACION
	1	8000 62728	5	Vite	Screw	Vis	Schraube	Tornillo
	2	8000 48814	5	Rosetta	Washer	Rondelle	Scheibe	Arandela
	3	8000 83085	5	Molla	Spring	Ressort	Feder	Resorte
	4	8000 70467	1	Piatto spingidisco	Push disc plate	Pousser disque plaque	Stoben scheibe	Empujar disco
	5	8000 70551	1	Ralla	Washer	Rondelle	Unterlegscheibe	Arandela
	6	8000 70550	1	Gabbia assiale a rulli	Needle bearing cage	Cage a aiguilles	Nadelkfig	Sombrerete de cojinete
	7	8000 70549	1	Piattello	Disc	Disque	Scheibe	Disco
	8	8000 88822	1	Ass. gruppo dischi frizione (FCC)	Clutch disc group assy (FCC)	Groupe disques embr. compl. (FCC)	Kupplungscheibegruppe Kpl. (FCC)	Grupo discos embr. compl. (FCC)
	9	8000 H4193	1	Rosetta	Washer	Rondelle	Scheibe	Arandela
	10	6BNO 21506	1	Sfera	Ball	Bille	Kugel	Esfera
	11	8000 H4192	1	Astina	Rod	Tige	Stange	Varilla
	12	8000 70552	1	Albero comando frizione	Shaft	Arbre	Welle	Eje
	13	8000 H4189	1	Campana frizione	Cluch housing	Cage embrayage	Kupplungskorb	Campana embrague
	14	8A00 65844	1	Disco ritegno	Disc	Disque	Scheibe	Disco
	15	8A00 31386	1	Dado M16	Nut M16	Ecrou M16	Mutter M16	Tuerca M16
	16	8000 29089	1	Rosetta	Washer	Rondelle	Scheibe	Arandela
	17	8000 70468	1	Mozzo portadischi	Hub disc carrier	Moyeuporte disque	Nabe	Cubo portadisco
	18	8000 46428	1	Rosetta	Washer	Rondelle	Scheibe	Arandela
	19	8000 H4655	1	Coppia ingranaggi trasmissione primaria (Z= 22/71)	Set of matched primary (Z= 22/71)	Engrenages transmission primaire (Z= 22/71)	Stirnraderpaar (Z= 22/71)	Copla engranaje transmisión primaria (Z= 22/71)
	20	8A00 25044	2	Cuscinetto a rullini	Needle bearing	Roulement à aiguilles	Nadelkäfig	Cojinete
	21	8A00 36849	1	Distanziale	Spacer	Entretoise	Distanzstück	Separador
	22	8A00 65845	1	Distanziale	Spacer	Entretoise	Distanzstück	Separador
	23	8000 92820	1	Distanziale	Spacer	Entretoise	Distanzstück	Separador
	24	63NO 16349	6	Rivetto	Rivet	Rivet	Niet	Remache
	25	8000 31378	6	Anello	Flexible coupling	Parafente	Gummidämpfer	Paratirones
	26	8000 54507	1	Linguetta a disco	Key	Clavette	Keil	Lengüeta americana
	27	8000 65923	1	Pignone (Z=16)	Pinion (Z=16)	Pignon (Z=16)	Ritzel (Z=16)	Engranaje (Z=16)
	28	8A00 04883	1	Dado	Nut	Ecrou	Mutter	Tuerca

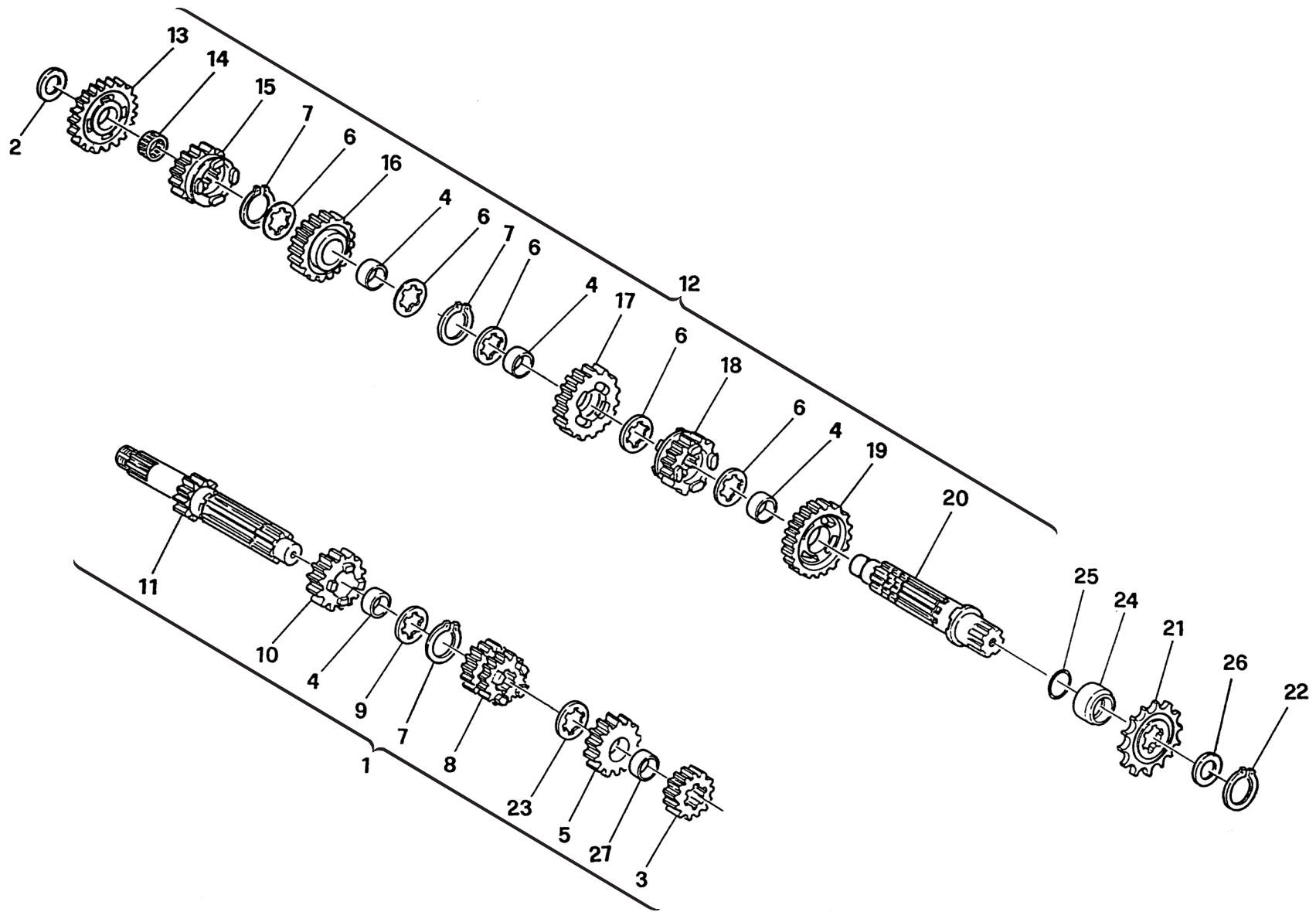

CAMBIO - TRANSMISSION - BOITE DE VITESSE - WECHSELGETRIEBE - CAMBIO

Note Notes Notes Marke Notas	Pos. No. N. Index Pos.	N. Cod. Code No. Nr. Code Code Nr N. Cod.	Q.tà Q.ty Q.te M.ge C.ad	DENOMINAZIONE	NAME	DESIGNATION	BESHREIBUNG	DENOMINACION
	1	8000 A8458	1	Assieme albero primario	Main shaft compl.	Arbre primaire compl.	Hauptwelle, Kpl.	Eje primario comp.
	2	8C00 68860	1	Rosetta di rasamento (0,6 mm)	Washer (0,6 mm)	Rondelle de butée (0,6 mm)	Ausgleichscheibe (0,6 mm)	Arandela de tope (0,6 mm)
	2	8D00 68860	1	Rosetta di rasamento (0,8 mm)	Washer (0,8 mm)	Rondelle de butée (0,8 mm)	Ausgleichscheibe (0,8 mm)	Arandela de tope (0,8 mm)
	3	8000 A8462	1	Ingr. seconda vel. A. P. (Z=13)	Gear counter shaft 2nd (Z =13)	Engrenage 2ème A.P. (Z=13)	Zahnrad 2 (Z=13)	Engr. 2° velocidad (Z=13)
	4	8A00 61261	4	Bussola	Bushing	Douille	Buchse	Buje
	5	8000 83033	1	Ingr. sesta vel A. P. (Z=21)	Gear, main shaft 6th (Z=21)	Pignon 6ème A.P. (Z =21)	Zahnrad 6 A.W. (Z =21)	Engranaje 6 velocidad (Z=21)
	6	8000 36023	5	Rosetta	Washer	Rondelle	Scheibe	Arandela
	7	8000 31768	3	Anello elastico	Snap ring	Circlip	Sprengring	Anillo elástico
	8	8000 A0301	1	Ingr. A.P. 3ª e 4ª (Z =19,20)	Gear shaft 3rd and 4th speed (Z =19,20)	Engrenage 3ème et 4 ème (Z =19,20)	Zahnrad A.W. 3 u. 4. Gang (Z =19,20)	Engr. 3° y 4° velocidad (Z =19,20)
	9	8000 36023	1	Rosetta	Washer	Rondelle	Scheibe	Arandela
	10	8000 A0300	1	Ingr. quinta vel. A. P. (Z=22)	Gear, main shaft 5th (Z=22)	Pignon A.P. 5ème (Z=22)	Zahnrad 5 A.W. (Z=22)	Engranaje 5° velocidad (Z=22)
	11	8000 99759	1	Albero primario (Z=14)	Main shaft (Z=14)	Arbre primaire (Z=14)	Hauptwelle (Z=14)	Eje primario (Z=14)
	12	8000 A8460	1	Assieme albero secondario	Layshaft compl.	Arbre secondaire compl.	Vorgelegewelle, Kpl.	Eje secundario comp.
	13	8000 99765	1	Ingr. prima vel. A. S. (Z=33)	Gear,counter shaft 1st (Z=33)	Pignon 1ère A.S. (Z=33)	Zahnrad 1 N.W. (Z=33)	Engr. 1° velocidad (Z=33)
	14	8000 40449	1	Cuscinetto a rullini	Needle bearing	Roulement à aiguilles	Nadelkäfig	Cojinete
	15	8000 99900	1	Ingr. quinta vel. A. S. (Z=26)	Gear counter shaft 5th (Z=26)	Pignon 5èmè A.S. (Z=26)	Zahnrad 5 N.W. (Z=26)	Engr. 5° velocidad (Z=26)
	16	8000 99872	1	Ingr. quarta vel. A. S. (Z=27)	Gear counter shaft 4th (Z=27)	Engrenage 4ème A.S. (Z=27)	Zahnrad 4 N.W. (Z=27)	Engr. 4° velocidad (Z=27)
	17	8000 99818	1	Ingran. terza vel. A. S. (Z=30)	Gear counter shaft 3rd (Z=30)	Pignon 3ème A.S. (Z=30)	Zahnrad 3 N.W. (Z=30)	Engr. 3° velocidad (Z=30)
	18	8000 83034	1	Ingr. sesta vel. A. S. (Z=21)	Gear counter shaft 6th (Z=21)	Pignon 6ème A.S. (Z =21)	Zahnrad 6 N.W. (Z=21)	Engr. 6° velocidad (Z=21)
	19	8000 A8461	1	Ingran. sec. vel. A. S. (Z=25)	Gear counter shaft 2nd (Z=25)	Pignon 2ème A.S. (Z=25)	Zahnrad 2 N.W. (Z=25)	Engr. 2° velocidad (Z=25)
	20	8000 A1909	1	Albero secondario	Secondary shaft	Arbre secondaire	Neben welle	Arbol secundario
R	21	8000 82469	1	Pignone uscita cambio (Z=12)	Pinion (Z=12)	Pignon (Z=12)	Ritzel (Z=12)	Piñón (Z=12)
R	21	8B00 82469	1	Pignone uscita cambio (Z=14)	Pinion (Z=14)	Pignon (Z=14)	Ritzel (Z=14)	Piñón (Z=14)
R	21	8C00 82469	1	Pignone uscita cambio (Z=15)	Pinion (Z=15)	Pignon (Z=15)	Ritzel (Z=15)	Piñón (Z=15)
S	21	8A00 82469	1	Pignone uscita cambio (Z=13)	Pinion (Z=13)	Pignon (Z=13)	Ritzel (Z=13)	Piñón (Z=13)
	22	66NA 21208	1	Anello elastico	Snap ring	Circlip	Sprengring	Anillo elástico
	23	8E00 48590	1	Rosetta (SP= 0,6 mm)	Washer (SP= 0,6 mm)	Rondelle (SP= 0,6 mm)	Scheibe (SP= 0,6 mm)	Arandela (SP= 0,6 mm)
	24	8000 31744	1	Distanziale	Spacer	Entretoise	Distanzstück	Separador
	25	8000 19789	1	Anello di tenuta	O Ring	Bague OR	O Ring	Anillo OR
	26	8E00 07989	1	Rosetta di rasamento (0,8 mm)	Washer (0,8 mm)	Rondelle de butée (0,8 mm)	Ausgleichscheibe (0,8 mm)	Arandela de tope (0,8 mm)
	26	8G00 07989	1	Rosetta di rasamento (1,0 mm)	Washer (1,0 mm)	Rondelle de butée (1,0 mm)	Ausgleichscheibe (1,0 mm)	Arandela de tope (1,0 mm)
	27	8000 66955	1	Bussola	Bushing	Douille	Buchse	Buje

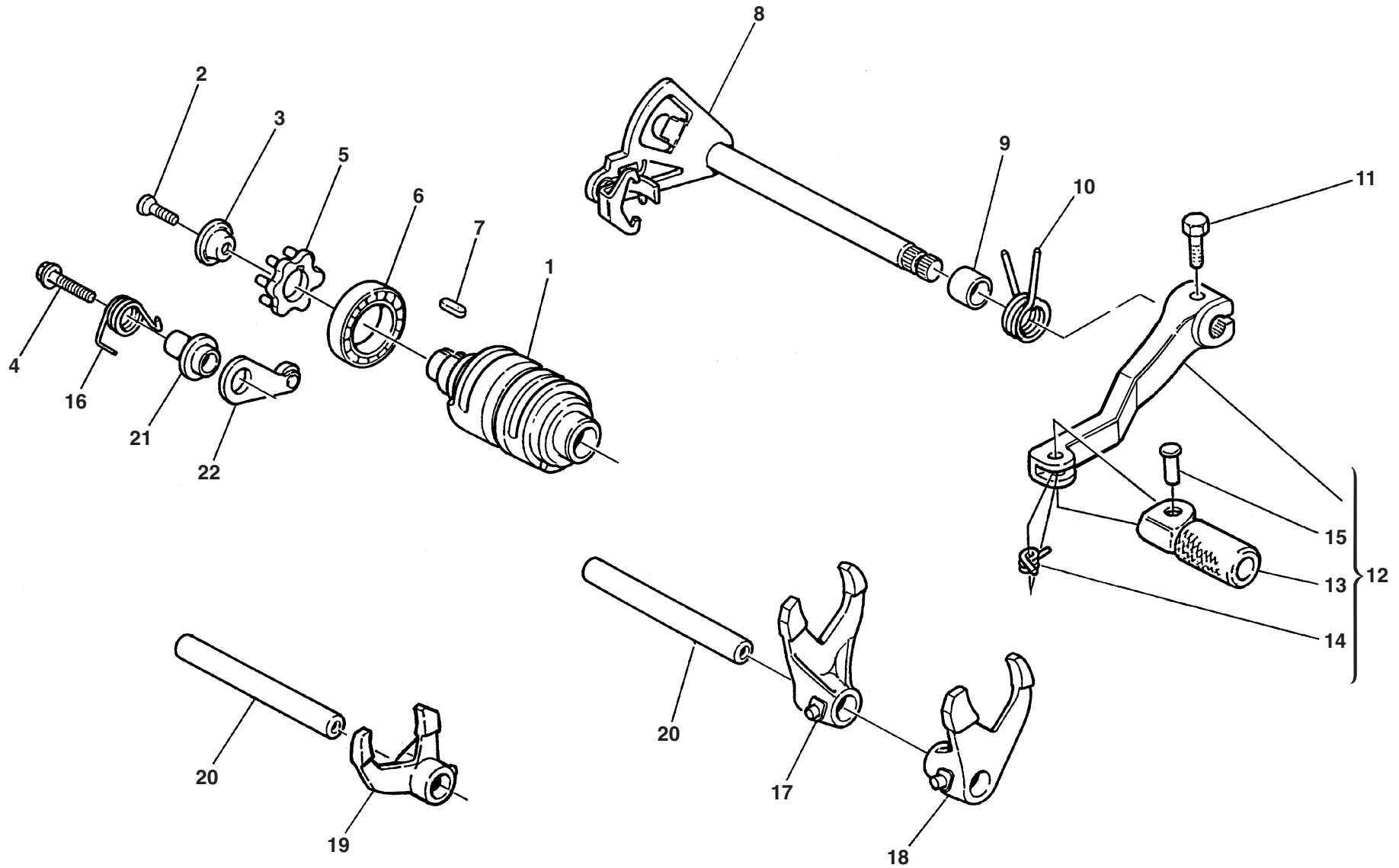

COMANDO CAMBIO - SHIFTER - COMMANDE DE VITESSE - GANGSCHALTUNG - MANDO CAMBIO



Note Notes Notes Marke Notas	Pos. No. N. Index Pos.	N. Cod. Code No. Nr. Code Code Nr N. Cod.	Q.tà Q.ty Q.te M.ge C.ad	DENOMINAZIONE	NAME	DESIGNATION	BESHREIBUNG	DENOMINACION
	1	8000 83010	1	Albero comando forcelle	Shaft	Arbre	Welle	Arbol
	2	8000 26970	1	Vite	Screw	Vis	Schraube	Tornillo
	3	8000 38708	1	Rosetta	Washer	Rondelle	Scheibe	Arandela
	4	Z000 62730	1	Vite	Screw	Vis	Schraube	Tornillo
	5	8000 38706	1	Rocchetto	Sprocket	Rochet	Spule	Piñón
	6	8000 65884	1	Cuscinetto a sfere	Ball bearing	Roulement à billes	Kugellager	Cojinete de bolas
	7	8000 38707	1	Linguetta	Woodruff key	Clé woodruff	Federkeil	Lengüeta
	8	8000 65975	1	Assieme selettore	Selector assembly	Ensemble sélecteur	Aggregat Wählschalter	Juego selector
	9	8A00 46226	1	Distanziale	Spacer	Entretoise	Distanzstück	Separador
	10	8000 46225	1	Molla	Spring	Ressort	Feder	Resorte
	11	8000 62728	1	Vite	Screw	Vis	Schraube	Tornillo
	12	8000 A3488	1	Ass. leva comando cambio	Gearchange lever	Levier comm.vitesse	Schalthebe	Palanca del cambio
	13	8A00 A3485	1	Pedalino per leva comando cambio	Gearchange level pedal	Pedale	Pedal	Pedal
	14	8000 70216	1	Molla per pedalino comando cambio	Spring	Ressort	Feder	Resorte
	15	8000 99744	1	Ribattino	Rivet	Rivet	Niet	Remache
	16	8000 65921	1	Molla	Spring	Ressort	Feder	Resorte
	17	8000 67010	1	Forcella ingr. 1ª, 4ª vel.	Fork gear shifter 1st, 4th	Fourche 1ère, 4ème	Schaltgabel 1, 4 Gang	Horquilla compl. engr. 1°, 4°
	18	8A00 67011	1	Forcella ingr. 2ª e 3ª vel.	2nd & 3rd gear control fork	Fourche c.de 2ème & 3ème	Gabel f. Zahnr. 2 & 3 Gesch.	Horquilla engr. 2° y 3° vel.
	19	8000 67012	1	Forcella ingr. 5ª e 6ª vel.	5th & 6th gear control fork	Fourche c.de 5ème & 6ème	Gabel Zahnr. 5 & 6 Geschw.	Horquilla engr. 5° y 6° vel.
	20	8000 35876	2	Perno forcella	Pin	Pivot	Stift	Perno
	21	8000 66962	1	Bussola	Bushing	Douille	Buchse	Buje
	22	8A00 65895	1	Saltarello fissa marce	Gear fixing click	Cliquet	Strumhaken	Salt. fijo marchas

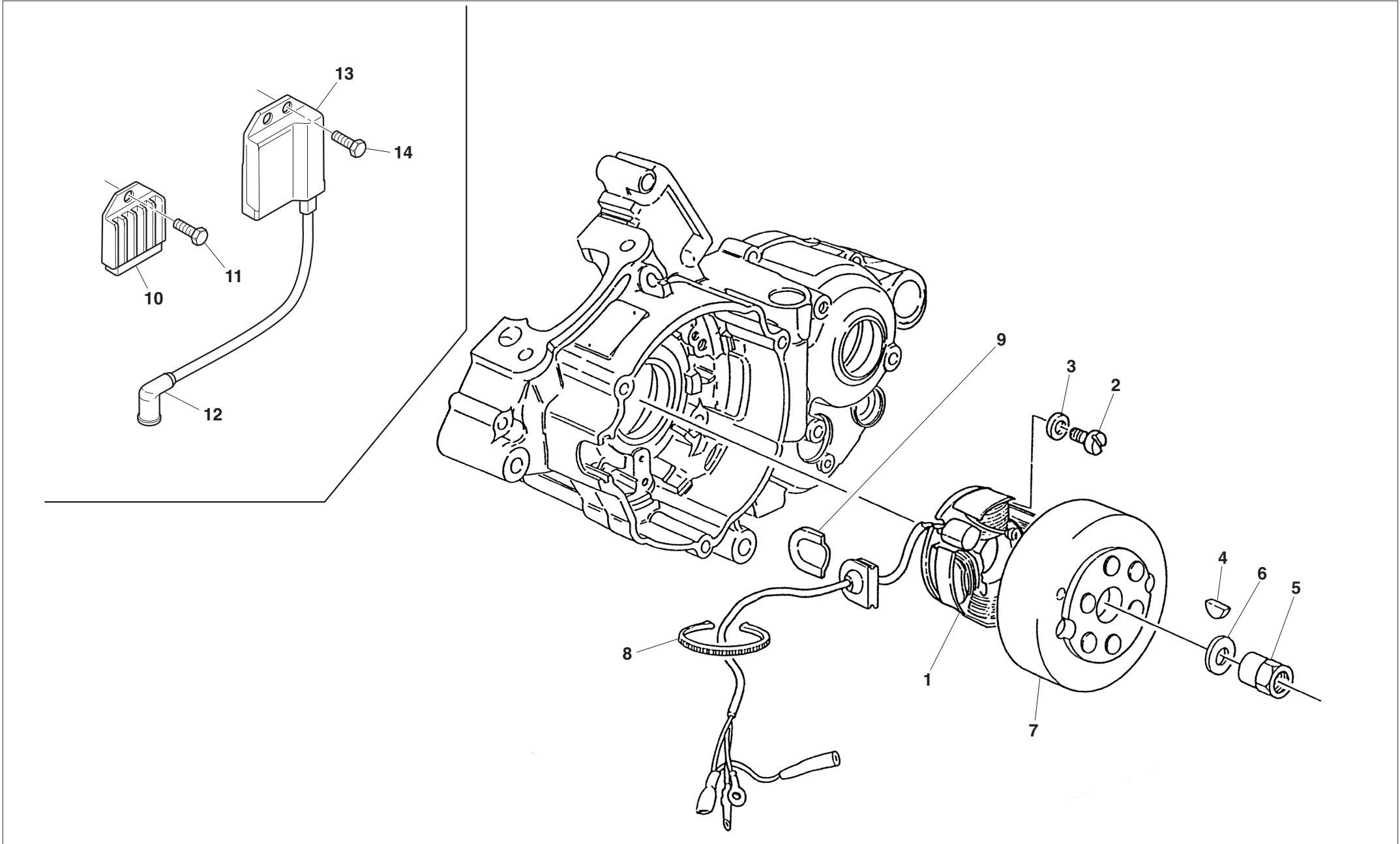

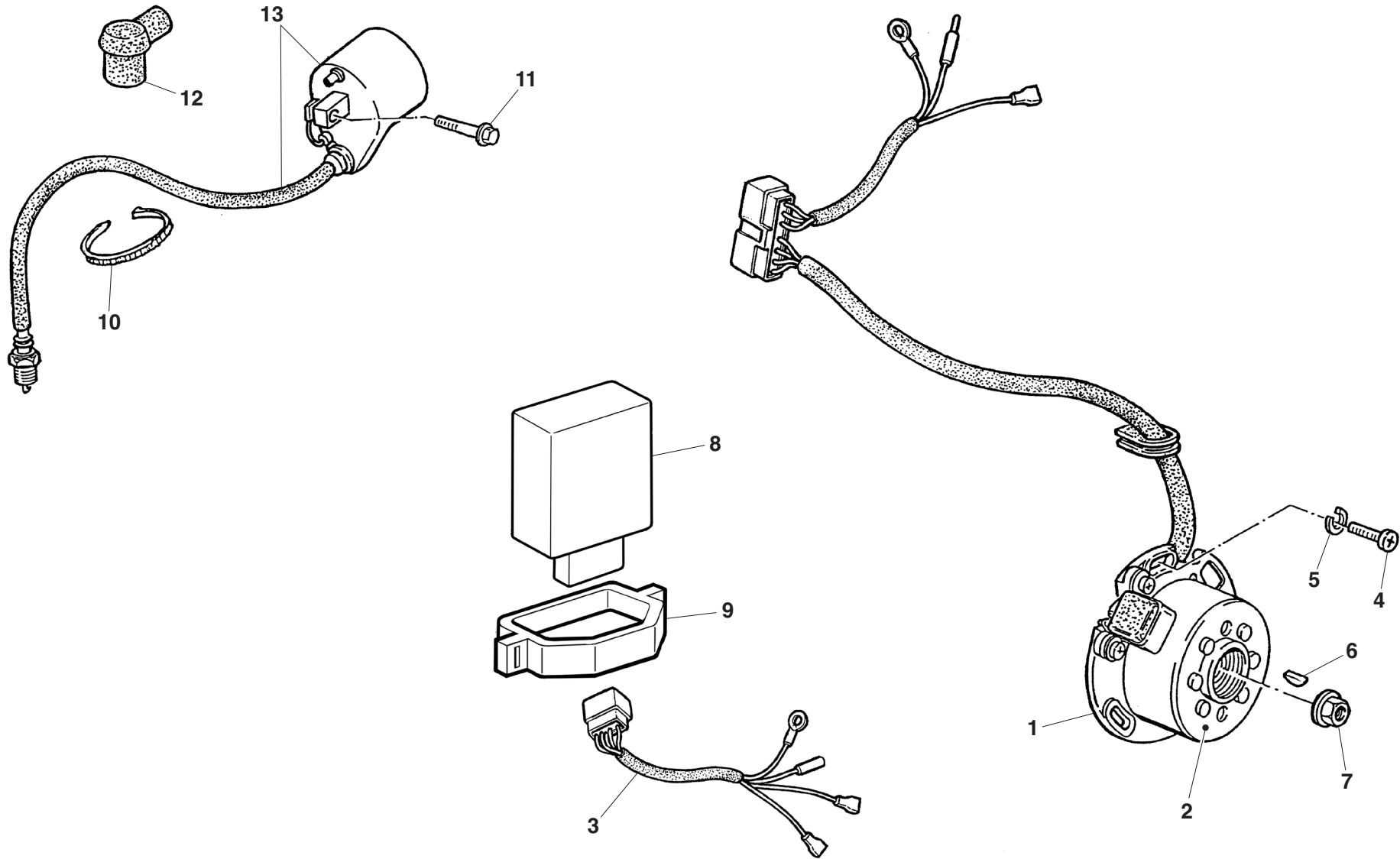

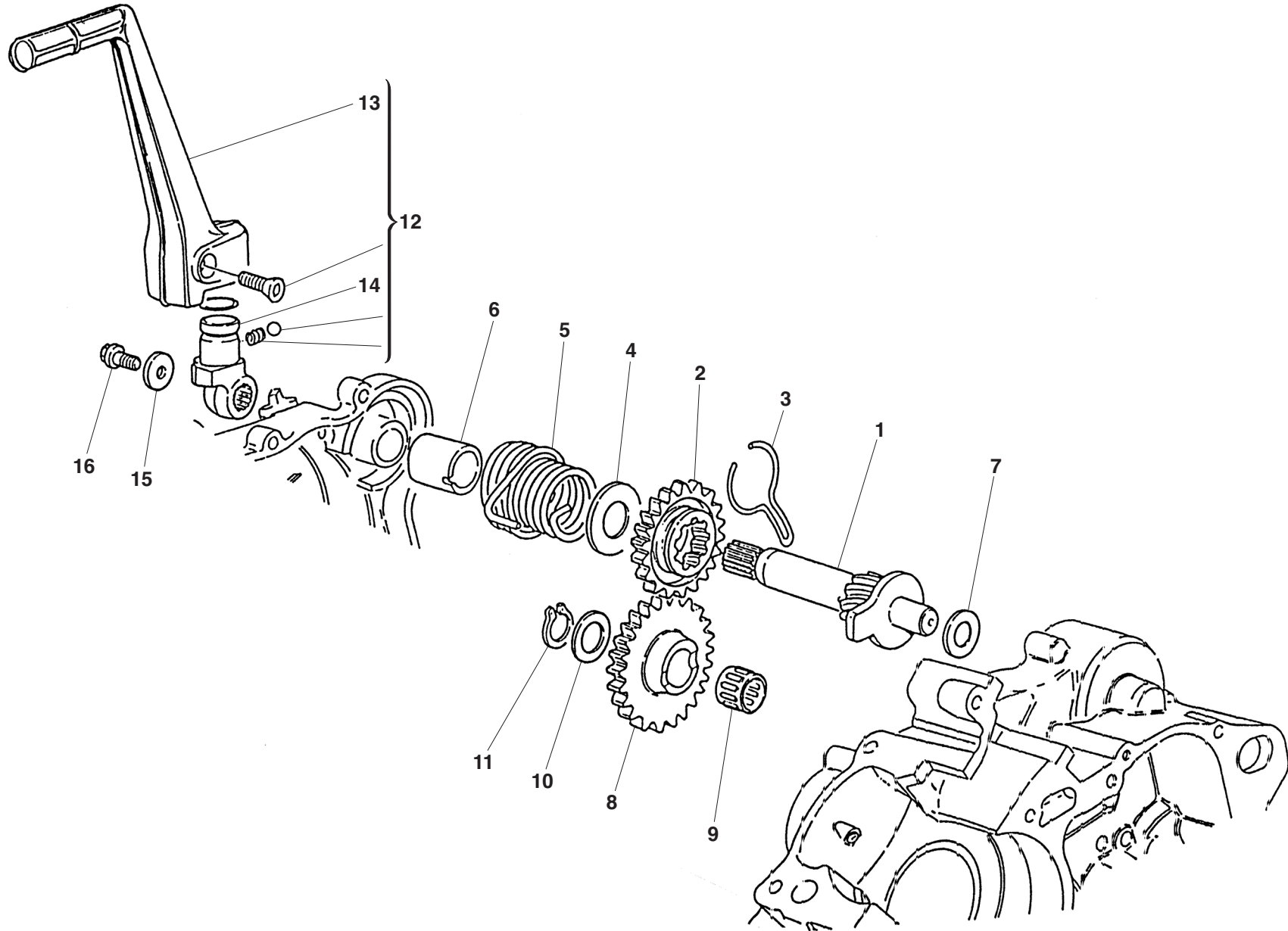

WR 125/2013
CR 125/2013

TAVOLA - DRAWING
TABLE - BILD - TABLA

11

AVVIAMENTO A PEDALE - KICK STARTER
PEDAL DE MISE EN MARCHE - ANLASSER
PUESTA EN MARCHA A PEDAL



Note Notes Notes Marke Notas	Pos. No. Index Pos.	N. Cod. Code No. Nr. Code Code Nr N. Cod.	Q.tà Q.ty Q.te M.ge C.ad	DENOMINAZIONE	NAME	DESIGNATION	BESHREIBUNG	DENOMINACION
	1	8000 67017	1	Albero avviamento	Starter crank shaft	Arbre dedémarrage	Kickstarterwellw	Eje arranque
	2	8000 67015	1	Ingranaggio (Z=22)	Gear (Z=22)	Engrenage (Z=22)	Zahnrad (Z=22)	Engranaje (Z=22)
	3	8000 67016	1	Molla di frizione	Spring	Resort	Feder	Resorte
	4	8E00 18282	1	Rosetta	Washer	Rondelle	Scheibe	Arandela
	5	8000 83095	1	Molla di ritorno leva	Spring	Resort	Feder	Resorte
	6	8000 67020	1	Distanziale	Spacer	Entretoise	Distanzstück	Separador
	7	8D00 10789	1	Rosetta	Washer	Rondelle	Scheibe	Arandela
	8	8000 67013	1	Ingranaggio di rinvio (Z=25)	Gear (Z=25)	Engrenage (Z=25)	Zahnrad (Z=25)	Engranaje (Z=25)
	9	8A00 19946	1	Cuscinetto a rulli	Needle bearing	Roulement à l'aguiilles	Nadelkafig	Cojinete
	10	8E00 01049	1	Rosetta	Washer	Rondelle	Scheibe	Arandela
	11	66N0 21203	1	Anello elastico	Snap ring	Circlip	Sprengring	Anillo elástico
	12	8000 H0658	1	Leva avviamento completa	Starter lever assy	Levier démarrage compl.	Hebelanlasser kpl.	Palanca arranque compl.
	13	8000 H0659	1	Leva avviamento	Lever	Levier	Hebelanlasser	Palanca
	14	8000 67047	1	Mozzetto	Hub	Moyeau	Radnabe	Cubo
	15	Z000 30319	1	Rosetta	Washer	Rondelle	Scheibe	Arandela
	16	8000 62725	1	Vite	Screw	Vis	Schraube	Tornillo

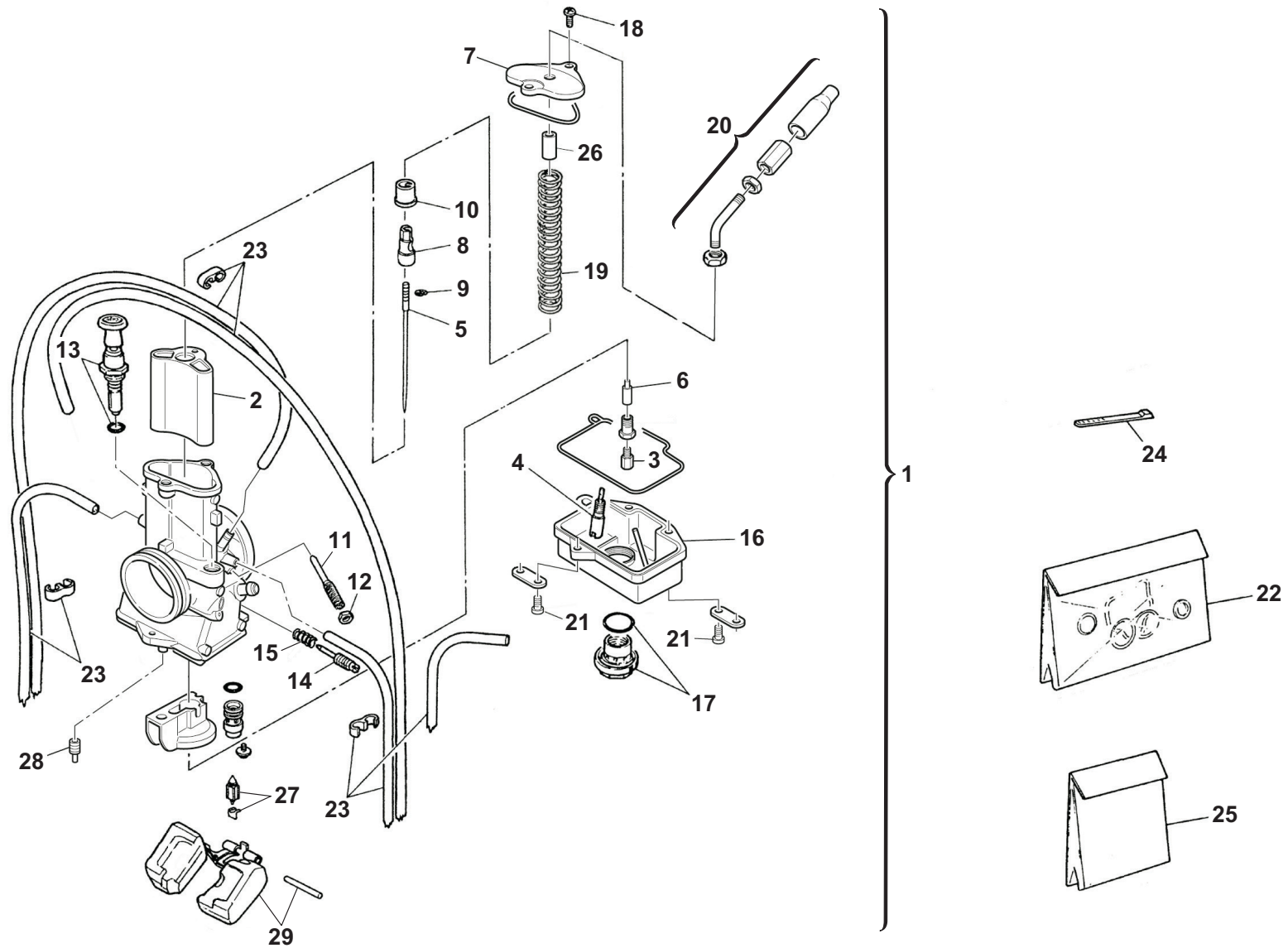

**CARBURATORE - CARBURETOR
CARBURATEUR - VERGASER
CARBURADOR**



Note Notes Notas	Pos. No. Index Pos.	N. Cod. Code No. Nr. Code Code Nr N. Cod.	Q.tà Q.ty M.ge C.ad	DENOMINAZIONE	NAME	DESIGNATION	BESHREIBUNG	DENOMINACION
C	1	8000 H6500	1	Assieme carburatore EU-AUS-USA	Carburetor assy. EU-AUS-USA	Carburateur compl. EU-AUS-USA	Vergaser kpl. EU-AUS-USA	Carburador compl. EU-AUS-USA
W	1	8000 H0411	1	Assieme carburatore EU-AUS	Carburetor assy. EU-AUS	Carburateur compl. EU-AUS	Vergaser kpl. EU-AUS	Carburador compl. EU-AUS
W	1	8000 H6500	1	Assieme carburatore USA	Carburetor assy. USA	Carburateur compl. USA	Vergaser kpl. USA	Carburador compl. USA
CS	2	8000 H1786	1	Valvola gas (4.0)	Throttle valve (4.0)	Papillon de gaz (4.0)	Drosselklappe (4.0)	Válvula gaz (4.0)
WR	2	8000 H1786	1	Valvola gas (4.0) EU-AUS	Throttle valve (4.0) EU-AUS	Papillon de gaz (4.0) EU-AUS	Drosselklappe (4.0) EU-AUS	Válvula gaz (4.0) EU-AUS
WS	2	8000 H1786	1	Valvola gas (4.0) USA	Throttle valve (4.0) USA	Papillon de gaz (4.0) USA	Drosselklappe (4.0) USA	Válvula gaz (4.0) USA
WS	2	8A00 H1786	1	Valvola gas (5.0) EU-AUS	Throttle valve (5.0) EU-AUS	Papillon de gaz (5.0) EU-AUS	Drosselklappe (5.0) EU-AUS	Válvula gaz (5.0) EU-AUS
CS	3	8DD0 72310	1	Getto max. (460)	Main jet (460)	Gicleur principal (460)	Hauptdüse (460)	Chiclé máximo (460)
R	3	8CC0 72310	1	Getto max. (440)	Main jet (440)	Gicleur principal (440)	Hauptdüse (440)	Chiclé máximo (440)
R	3	8EE0 72310	1	Getto max. (450)	Main jet (450)	Gicleur principal (450)	Hauptdüse (450)	Chiclé máximo (450)
R	3	8FF0 72310	1	Getto max. (470)	Main jet (470)	Gicleur principal (470)	Hauptdüse (470)	Chiclé máximo (470)
R	3	8GG0 72310	1	Getto max. (480)	Main jet (480)	Gicleur principal (480)	Hauptdüse (480)	Chiclé máximo (480)
R	3	8HH0 72310	1	Getto max. (490)	Main jet (490)	Gicleur principal (490)	Hauptdüse (490)	Chiclé máximo (490)
R	3	8X00 72310	1	Getto max. (410)	Main jet (410)	Gicleur principal (410)	Hauptdüse (410)	Chiclé máximo (410)
R	3	8Y00 72310	1	Getto max. (420)	Main jet (420)	Gicleur principal (420)	Hauptdüse (420)	Chiclé máximo (420)
R	3	8Z00 72310	1	Getto max. (430)	Main jet (430)	Gicleur principal (430)	Hauptdüse (430)	Chiclé máximo (430)
WR	3	8DD0 72310	1	Getto max. (460) EU-AUS	Main jet (460) EU-AUS	Gicleur principal (460) EU-AUS	Hauptdüse (460) EU-AUS	Chiclé máximo (460) EU-AUS
WS	3	8DD0 72310	1	Getto max. (460) USA	Main jet (460) USA	Gicleur principal (460) USA	Hauptdüse (460) USA	Chiclé máximo (460) USA
WS	3	8U00 72310	1	Getto max. (380) EU-AUS	Main jet (380) EU-AUS	Gicleur principal (380) EU-AUS	Hauptdüse (380) EU-AUS	Chiclé máximo (380) EU-AUS
CS	4	8M00 A1804	1	Getto minimo (45)	Idle jet (45)	Gicleur minimum (45)	Leerlaufdüse (45)	Chiclé mínimo (45)
R	4	8B00 A1804	1	Getto minimo (35)	Idle jet (35)	Gicleur minimum (35)	Leerlaufdüse (35)	Chiclé mínimo (35)
R	4	8B00 A1804	1	Getto minimo (35)	Idle jet (35)	Gicleur minimum (35)	Leerlaufdüse (35)	Chiclé mínimo (35)
R	4	8E00 A1804	1	Getto minimo (50)	Idle jet (50)	Gicleur minimum (50)	Leerlaufdüse (50)	Chiclé mínimo (50)
R	4	8L00 A1804	1	Getto minimo (40)	Idle jet (40)	Gicleur minimum (40)	Leerlaufdüse (40)	Chiclé mínimo (40)
WR	4	8M00 A1804	1	Getto minimo (45) EU-AUS	Idle jet (45) EU-AUS	Gicleur minimum (45) EU-AUS	Leerlaufdüse (45) EU-AUS	Chiclé mínimo (45) EU-AUS
WS	4	8M00 A1804	1	Getto minimo (45) USA	Idle jet (45) USA	Gicleur minimum (45) USA	Leerlaufdüse (45) USA	Chiclé mínimo (45) USA
WS	4	8P00 A1804	1	Getto minimo (15) EU-AUS	Idle jet (15) EU-AUS	Gicleur minimum (15) EU-AUS	Leerlaufdüse (15) EU-AUS	Chiclé mínimo (15) EU-AUS
CS	5	8B00 H1785	1	Spillo conico USA	Needle USA	Pointeau conique USA	Kon. Nadel USA	Pasadòr cónico USA
WR	5	8B00 H1785	1	Spillo conico	Needle	Pointeau conique	Kon. Nadel	Pasadòr cónico
WS	5	8000 H1785	1	Spillo conico EU-AUS	Needle EU-AUS	Pointeau conique EU-AUS	Kon. Nadel EU-AUS	Pasadòr cónico EU-AUS
WS	5	8B00 H1785	1	Spillo conico USA	Needle USA	Pointeau conique USA	Kon. Nadel USA	Pasadòr cónico USA
	6	8000 H1809	1	Polverizzatore NJ-R-8	Fuel nozzle NJ-R-8	Pulvérisateur NJ-R-8	Einspritzdüse NJ-R-8	Pulverizadòr NJ-R-8
	7	8000 H1799	1	Coperchio	Cover	Couvercle	Deckel	Tapa

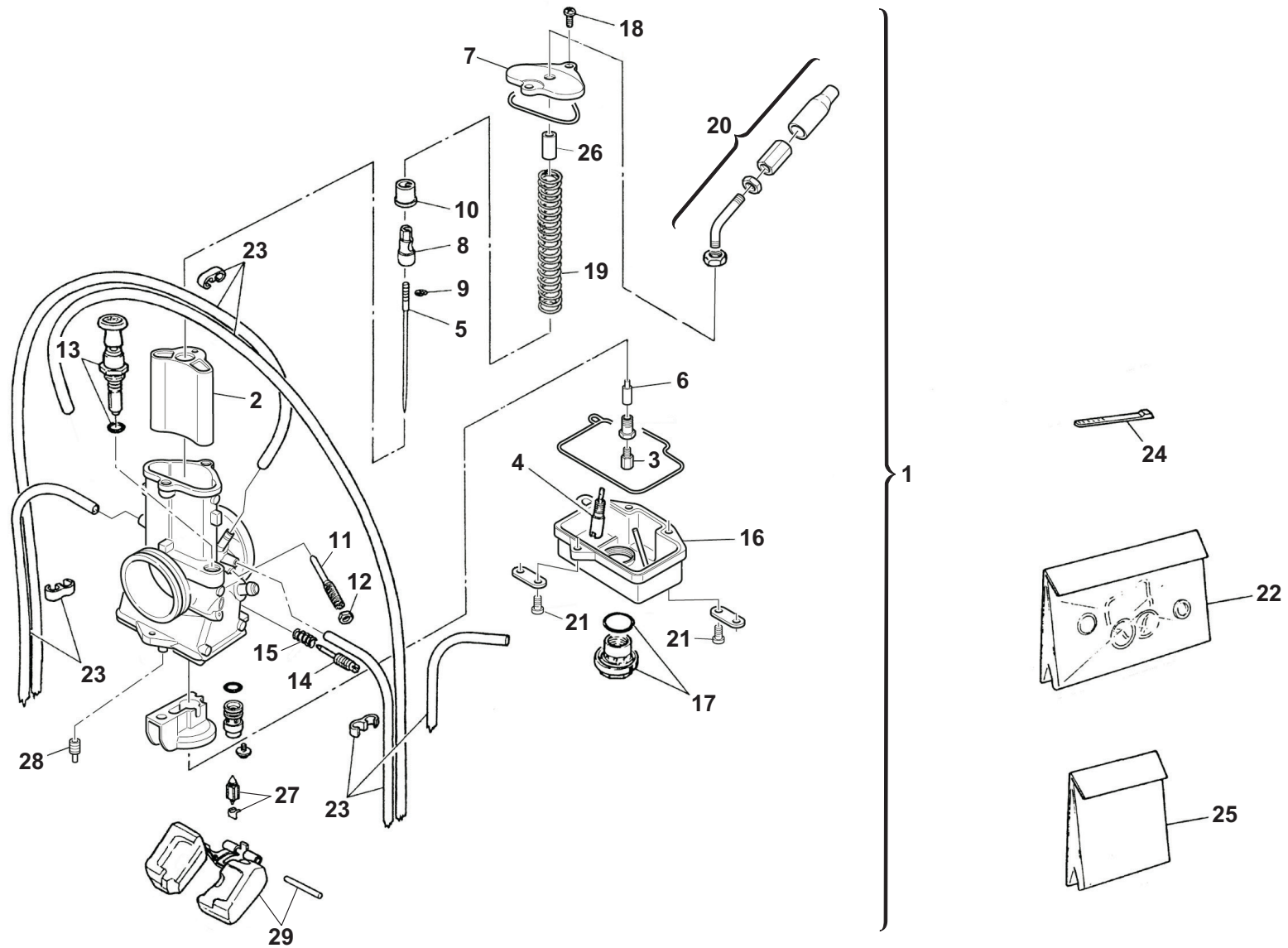

CARBURATORE - CARBURETOR
CARBURATEUR - VERGASER
CARBURADOR



Note Notes Notes Marke Notas	Pos. No. N. Index Pos.	N. Cod. Code No. Nr. Code Code Nr N. Cod.	Q.tà Q.ty Q.te M.ge C.ad	DENOMINAZIONE	NAME	DESIGNATION	BESHREIBUNG	DENOMINACION
	8	8000 H1800	1	Fermo spillo e molla	Retainer	Arret	Klammer	Pasadòr
	9	8000 H1801	1	Anello elastico	Snap ring	Circlip	Sprengring	Anillo elástico
	10	8000 86925	1	Guida molla	Spring seat	Siège ressort	Feder sitzring	Alojamiento resorte
	11	8000 86926	1	Vite regolazione minimo	Stop screw idle speed adj.	Fil de réglage	Reglerkabel	Trans. de regulacion
	12	8000 86927	1	Dado	Nut	Ecrou	Mutter	Tuerca
	13	8000 72327	1	Dispositivo avviamento	Starting device	Dispositif de démarrage	Startvorrichtung	Dispositivo arranque
	14	8000 H1803	1	Vite aria	Screw	Vis	Schraube	Tornillo
	15	8000 72329	1	Molla	Spring	Ressort	Feder	Resorte
	16	8000 H1802	1	Vaschetta	Chamber	Cuvette	Becken	Cubeta
	17	8000 H1804	1	Tappo+guarnizione	Plug+gasket	Bouchon+garniture	Stöpsel+Dichtung	Tapón+junta
	18	8000 H1790	2	Vite	Screw	Vis	Schraube	Tornillo
	19	8A00 72334	1	Molla	Spring	Ressort	Feder	Resorte
	20	8000 72318	1	Gruppo registro	Adjuster set	Groupe réglage	Kupplungsreglergruppe	Grupo regulaciòn
	21	8000 H1789	3	Vite	Screw	Vis	Schraube	Tornillo
	22	8000 H1788	1	Gruppo guarnizioni	Gasket set	Groupe garnitures	Dichtungssatz	Grupo juntas
	23	8000 H1791	1	Kit tubi sfiato	Breather pipe kit	Set tuyau	Rohrgruppe Kpl	Grupo tubos
	24	8000 21810	1	Fascetta	Clamp	Collier	Schelle	Banda
CS	25	8000 H0791	1	Kit getti (FULL POWER)	Jet kit (FULL POWER)	Kit gicleurs (FULL POWER)	Düse Kit (FULL POWER)	Kit chiclé (FULL POWER)
WR	25	8000 H0791	1	Kit getti (FULL POWER) EU	Jet kit (FULL POWER) EU	Kit gicleurs (FULL POWER) EU	Düse Kit (FULL POWER) EU	Kit chiclé (FULL POWER) EU
WS	25	8000 H0791	1	Kit getti (FULL POWER) USA	Jet kit (FULL POWER) USA	Kit gicleurs (FULL POWER) USA	Düse Kit (FULL POWER) USA	Kit chiclé (FULL POWER) USA
WS	26	8A00 A6249	1	Distanziale EU	Spacer EU	Entretoise EU	Distanzstück EU	Separador EU
	27	8000 H7437	1	Valvola a ago - 3,8	Needle valve - 3,8	Soupape à pointeau - 3,8	Nadelventil - 3,8	Válvula de aguja - 3,8
CS	28	8000 H1787	1	Getto aria starter (80)	Starter air jet (80)	Gicleur air démarrage (80)	Starterluftdüse (80)	Chiclé aire arranque (80)
WR	28	8000 H1787	1	Getto aria starter (80) EU	Starter air jet (80) EU	Gicleur air démarrage (80) EU	Starterluftdüse (80) EU	Chiclé aire arranque (80) EU
WS	28	8000 H1787	1	Getto aria starter (80) USA	Starter air jet (80) USA	Gicleur air démarrage (80) USA	Starterluftdüse (80) USA	Chiclé aire arranque (80) USA
WS	28	8A00 H1787	1	Getto aria starter (50) EU	Starter air jet (50) EU	Gicleur air démarrage (50) EU	Starterluftdüse (50) EU	Chiclé aire arranque (50) EU
	29	8000 H7436	1	Galleggiante+perno	Float+pin	Flotteur+pivot	Schwimmer+Bolzen	Flotador+perno

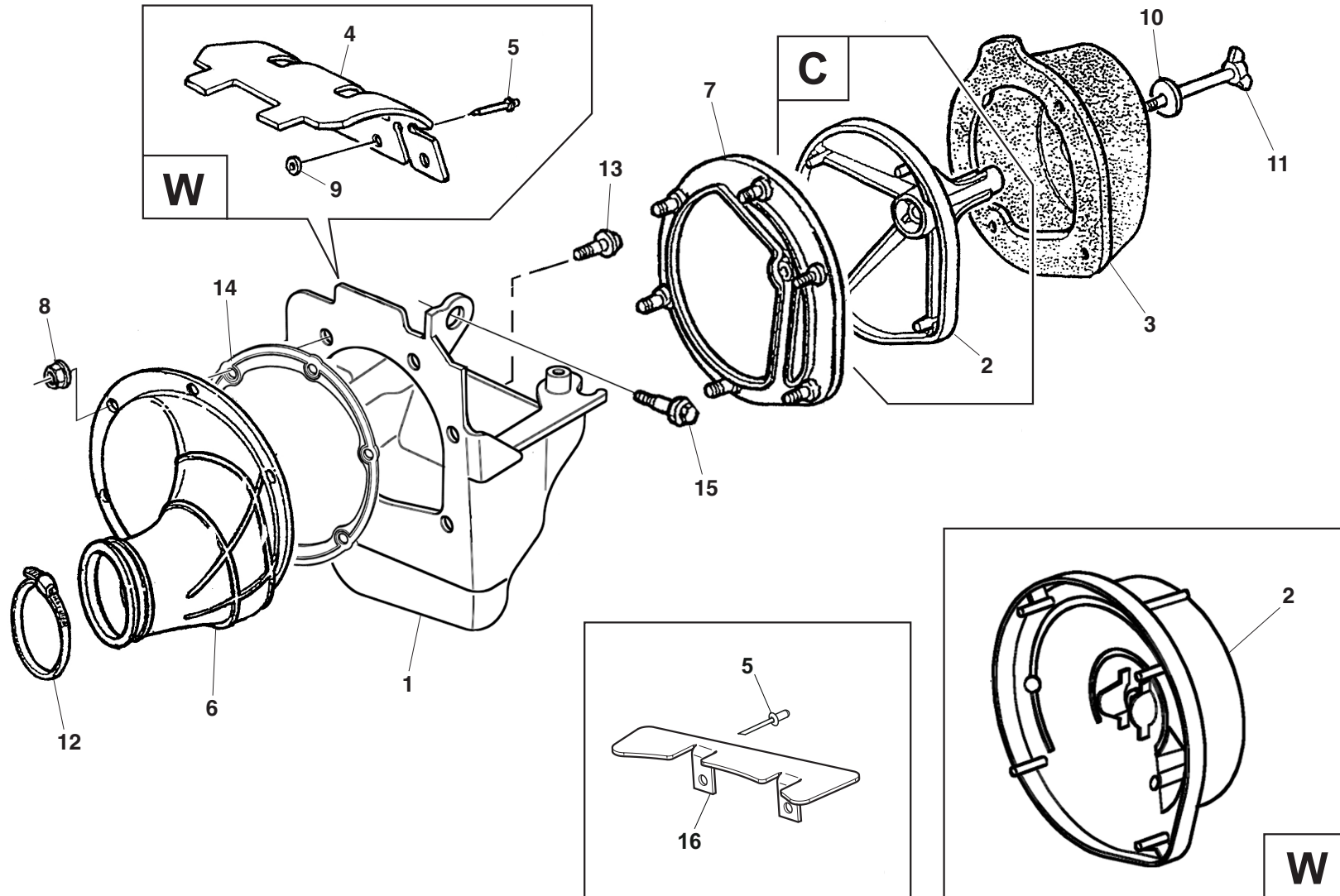

WR 125/2013
CR 125/2013

TAVOLA - DRAWING
TABLE - BILD - TABLA

13

FILTRO ARIA - AIR FILTER
FILTRE AIRE - LUFTFILTER
FILTRO DE AIRE



Note Notes Notes Marke Notas	Pos. No. Index Pos.	N. Cod. Code No. Nr. Code Code Nr N. Cod.	Q.tà Q.ty Q.te M.ge C.ad	DENOMINAZIONE	NAME	DESIGNATION	BESHREIBUNG	DENOMINACION
	1	8000 H0054	1	Scatola filtro aria	Air filter box	Boitre filtre	Filterkasten	Caja filtro aire
C	2	8000 69549	1	Gabbia filtro	Cleaner cage	Cage pour filtre	Filterkafig	Caja filtro
W	2	8000 H0805	1	Gabbia filtro	Cleaner cage	Cage pour filtre	Filterkafig	Caja filtro
	3	8000 72641	1	Filtro aria	Air filter	Filtre à air	Luftfilter	Filtro aire
W	4	8000 95898	1	Protezione	Guard	Protection	Schutz	Protección
	5	8000 33371	4	Rivetto	Rivet	Rivet	Niet	Remache
	6	8000 H0116	1	Raccordo	Union	Raccord	Anschluss	Empalme
	7	8000 H3013	1	Flangia	Flange	Bride	Flansch	Brida
	8	Z000 40718	6	Dado	Nut	Ecrou	Mutter	Tuerca
W	9	62ND 15547	4	Rosetta	Washer	Rondelle	Scheibe	Arandela
	10	62ND 15549	1	Rosetta	Washer	Rondelle	Scheibe	Arandela
	11	ZA00 37947	1	Vite	Screw	Vis	Schraube	Tornillo
	12	8E00 99475	1	Fascetta	Clamp	Collier	Schelle	Banda
	13	8B00 A8421	2	Vite	Screw	Vis	Schraube	Tornillo
	14	8000 B0575	1	Rosetta	Washer	Rondelle	Scheibe	Arandela
	15	8A00 A8421	1	Vite	Screw	Vis	Schraube	Tornillo
	16	8000 H7058	1	Protezione	Guard	Protection	Schutz	Protección

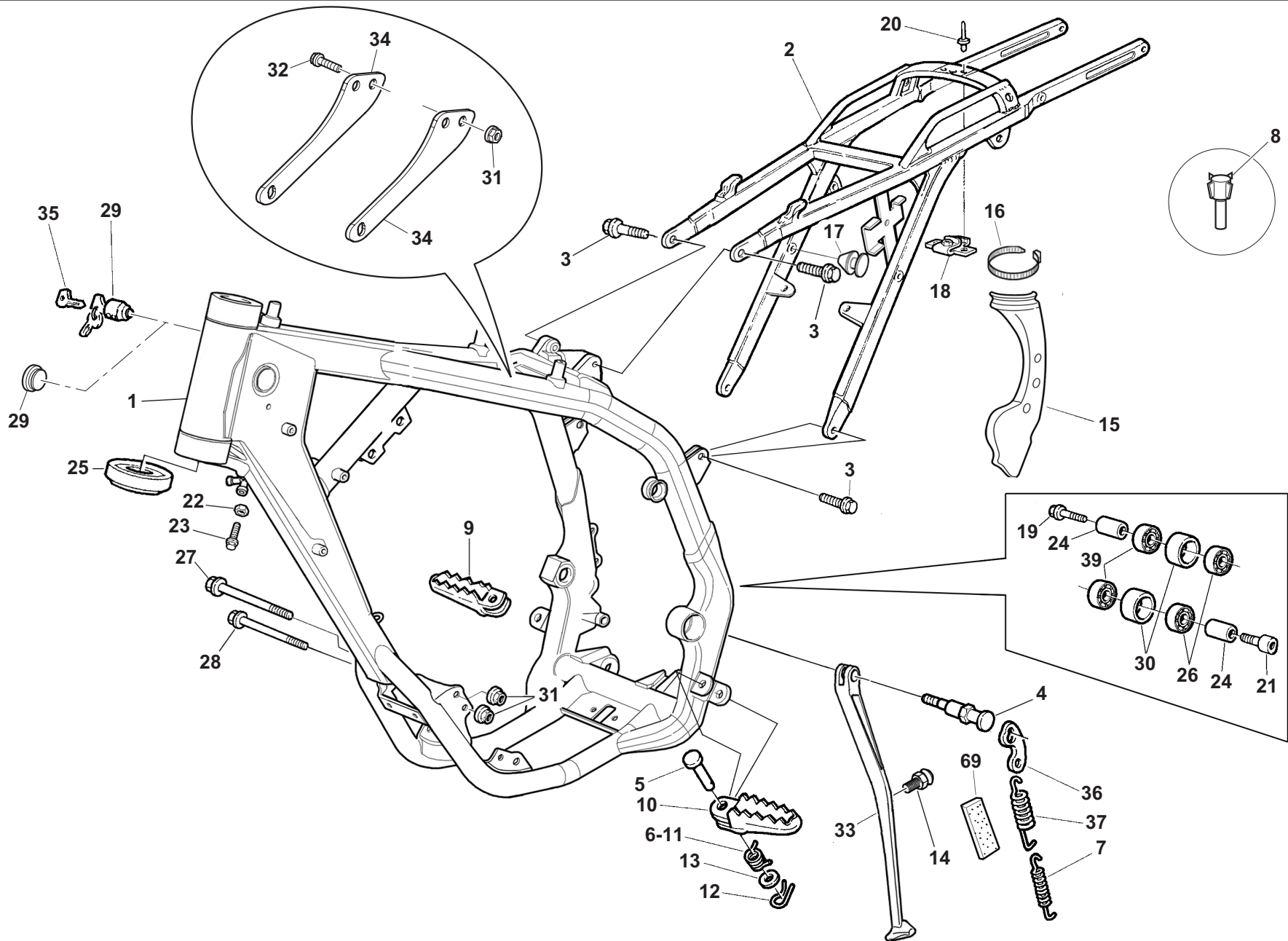

WR 125/2013
CR 125/2013

TAVOLA - DRAWING
TABLE - BILD - TABLA

14

TELAIO, PEDANE - FRAME, FOOT RESTS
CADRE, REPOSE PIEDS - RAHMEN, FUSSBRETT
BASTIDOR, REPOSAPIES



Note Notes Notes Marke Notas	Pos. No. N. Index Pos.	N. Cod. Code No. Nr. Code Code Nr N. Cod.	Q.tà Q.ty Q.te M.ge C.ad	DENOMINAZIONE	NAME	DESIGNATION	BESHREIBUNG	DENOMINACION
C	1	8000 H6845	1	Telaio anteriore	Front frame	Chassis antérieur	Rahmen vorrdrer	Bastidor delantero
W	1	8000 H6846	1	Telaio anteriore	Front frame	Chassis antérieur	Rahmen vorrdrer	Bastidor delantero
	2	8000 H1563	1	Telaio posteriore	Rear frame side	Chassis arrière	Sattelbrücke	Cuadro posterior
	3	Z000 69056	4	Vite flangiata	Flange bolt	Boulon de bride	Flanschschraube	Perno de reborde
W	4	8000 97976	1	Vite	Screw	Vis	Schraube	Tornillo
	5	Y000 73140	2	Perno	Pin	Pivot	Bolzen	Perno
	6	8000 96907	1	Molla Sx	L.H. spring	Ressort G.	Feder L.	Resorte lzq.
W	7	8000 A0268	1	Molla interna	Spring	Ressort	Feder	Resorte
	8	8000 48966	1	Rivetto	Rivet	Rivet	Niet	Remache
	9	80A0 89953	1	Pedana destra	R.H. foot-rest	Repose-pieds D.	R. Fussraste	Pedal delnt. der. compl.
	10	80A0 89962	1	Pedana sinistra	L.H. foot-rest	Repose-pieds G.	L. Fussraste	Pedal delant. izq. compl.
	11	8000 96908	1	Molla Dx	R.H. spring	Ressort D.	Feder R.	Resorte Der.
	12	64ND 20068	2	Copiglia	Split pin	Goupille	Splint	Clavija
	13	ZA00 01815	2	Rosetta	Washer	Rondelle	Scheibe	Arandela
	14	8000 H0235	1	Perno molla	Spring pivot	Axe ressort	Federzapfen	Perno muelle
	15	8000 H3435	1	Protezione telaio Sx	L.H. frame guard	Protection chassis G.	Rahmenschutz Links	Protección bastidor izquierda
	16	8000 56444	1	Fascetta	Clamp	Collier	Schelle	Banda
	17	8000 B0841	1	Tappo	Plug	Bouchon	Verschluss	Tapón
	18	8000 69150	1	Piastrina	Plate	Plaque	Platte	Placa
	19	Z000 62796	1	Vite	Screw	Vis	Schraube	Tornillo
	20	8000 33373	2	Rivetto	Rivet	Rivet	Niet	Remache
	21	60ND 02559	1	Vite	Screw	Vis	Schraube	Tornillo
	22	Z000 17810	2	Dado	Nut	Ecrou	Mutter	Tuerca
	23	ZE00 61121	2	Vite	Screw	Vis	Schraube	Tornillo
	24	8A00 59434	2	Distanziale	Spacer	Entretoise	Distanzstück	Separador
	25	8000 87243	2	Cuscinetto	Bearing	Roulement	Kugellager	Cojinete
	26	8000 63312	4	Cuscinetto	Bearing	Roulement	Kugellager	Cojinete
	27	YN00 73458	1	Vite	Screw	Vis	Schraube	Tornillo
	28	YP00 73458	1	Vite	Screw	Vis	Schraube	Tornillo
WX	29	8000 43391	1	Serratura antifurto completa	Anti-left lock assy	Serrure anti-vol compl.	Sicherheitsschloss kpl.	Cerradura compl.
WU	29	8000 H7823	1	Tappo	Plug	Bouchon	Verschluss	Tapón
	30	8AA0 59433	2	Rullo catena	Roller	Aiguille	Rolle	Rodillo
	31	Y000 43928	4	Dado	Nut	Ecrou	Mutter	Tuerca

SOSPENSIONE ANTERIORE - FRONT FORK ASSEMBLY
SUSPENSION AVANT - VORDERTELESKOPGABEL
SUSPENSION DELANTERA
TAVOLA - DRAWING
TABLE - BILD - TABLA**15**

Note Notes Marke Notas	Pos. No. N. Index Pos.	N. Cod. Code No. Nr. Code Code Nr N. Cod.	Q.tà Q.ty Q.te M.ge C.ad	DENOMINAZIONE	NAME	DESIGNATION	BESHREIBUNG	DENOMINACION
	1	8000 H2661	2	Rosetta piana	Washer	Rondelle	Scheibe	Arandela
	2	8000 H2693	2	Anello OR	O-Ring	Bague OR	O-Ring	Anillo OR
	3	8000 H2689	2	Valvola di fondo compl.	Compression base valve assy	Clapet de pied compl.	Boden Ventil Komplett	Válvula de pie compl.
	4	8000 H2694	2	Anello OR	O-Ring	Bague OR	O-Ring	Anillo OR
	5	8000 H2696	2	Mozzetto	Hub	Moyeau	Radnabe	Cubo
	6	8000 74842	2	Catadiottro ambra (CDN-AUS)	Reflector amber (CDN-AUS)	Catadioptrique ambre (CDN-AUS)	Rückstrahler Amber (CDN-AUS)	Catafaros àmbra (CDN-AUS)
	7	ZA00 84658	2	Vite	Screw	Vis	Schraube	Tornillo
	8	80A0 A0633	1	Piastrina (codice colore G) Nero	Plate (color code G) Black	Plaquette (code couleur G) Noir	Plättchen (Code Farbe G) Schwarz	Placa (còdigo colòr G) Negro
	9	8000 H2695	2	Anello OR	O-Ring	Bague OR	O-Ring	Anillo OR
	10	8000 A8423	6	Vite M6-L8	Screw M6-L8	Vis M6-L8	Schraube M6-L8	Tornillo M6-L8
	11	8000 H2656	2	Portastelo	Outer tube	Tuyau	Roh	Tubo
	12	8000 H2659	2	Bussola	Bushing	Douille	Buchse	Manguito
	13	8000 H2691	2	Scodellino	Cup	Cuvette	Teller	Cubeta
	14	8000 H2662	2	Anello di tenuta	Seal ring	Bague de retenue	Dichtring	Anillo de retención
	15	8000 H2663	2	Anello di fermo	Stop ring	Bague d'arrêt	Haltering	Anillo de retención
	16	8000 H2664	2	Raschiapolvere	Dust scraper	Racloir poudre	Pulverabschaber	Rascador de polvo
	17	8000 H2939	1	Gamba Sx. compl.	L.H. fork leg assy	Fourche compl. G.	Telegabel, Kpl. L.	Horquill izquierda compl.
	18	8000 H2940	1	Gamba Dx. compl.	R.H. fork leg assy	Fourche compl. D.	Telegabel, Kpl. R.	Horquill derecha compl.
	19	80A0 A8481	1	Protezione steli Sx (codice colore G) Nero	Guard L.H. (color code G) Black	Protection G. (code couleur G) Noir	Schutz L. (Code Farbe G) Schwarz	Protección izquierda (còdigo colòr G) Negro
	20	80A0 A8482	1	Protezione steli Dx (codice colore G) Nero	Guard R.H. (color code G) Black	Protection D. (code couleur G) Noir	Schutz R. (Code Farbe G) Schwarz	Protección derecha (còdigo colòr G) Negro
	21	8000 H2688	2	Gruppo pompante compl.	Damping element compl.	Amortissement compl.	Schwingungsdämpfer Kpl.	Bombeadora compl.
	22	8A00 B1959	4	Vite (M8x30 mm)	Screw (M8x30 mm)	Vis (M8x30 mm)	Schraube (M8x30 mm)	Tornillo (M8x30 mm)
	23	8000 H2690	2	Molla (K=4,2 N/mm)	Spring (K=4,2 N/mm)	Ressort (K=4,2 N/mm)	Feder (K=4,2 N/mm)	Resorte (K=4,2 N/mm)
	24	8000 H1358	1	Morsetto superiore	Hub	Moyeau	Radnabe	Cubo
	25	Z000 61314	2	Dado	Nut	Ecrou	Mutter	Tuerca
	26	60ND 01219	2	Vite (M10x65 mm)	Screw (M10x65 mm)	Vis (M10x65 mm)	Schraube (M10x65 mm)	Tornillo (M10x65 mm)
	27	8000 H3016	2	Distanziale	Spacer	Entretoise	Distanzstück	Separador
	28	8000 H1714	2	Distanziale	Spacer	Entretoise	Distanzstück	Separador
	29	8000 60234	4	Rosetta piana	Washer	Rondelle	Scheibe	Arandela
	30	8000 H1385	4	Gommino	Rubber pad	Pièce caoutchouc	Gummistück	Junta de goma
	31	8000 H1715	1	Morsetto inferiore Dx	Lower clamp R.H.	Etrier inf. D.	Untere Brücke R.	Brida inf. derecha

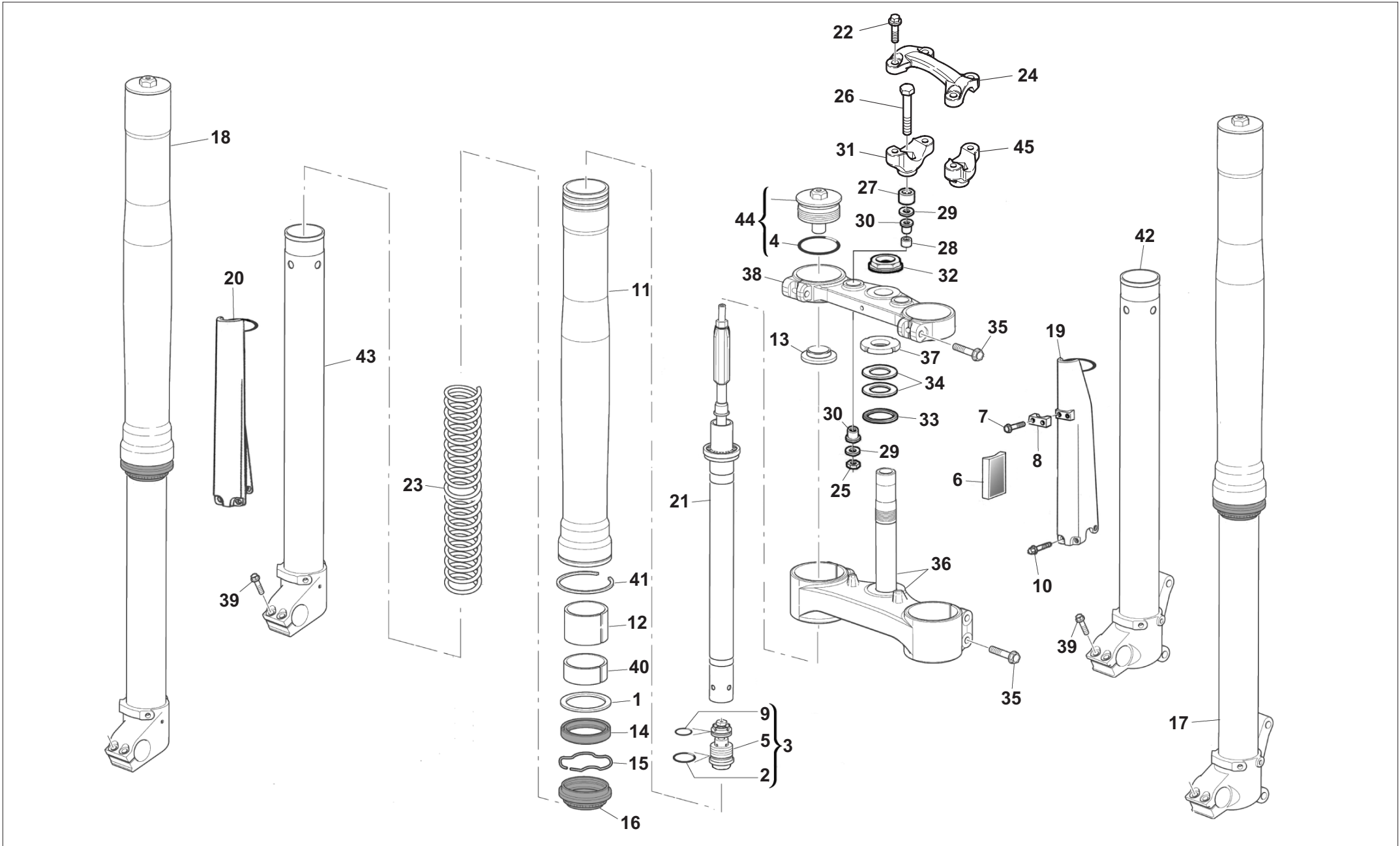

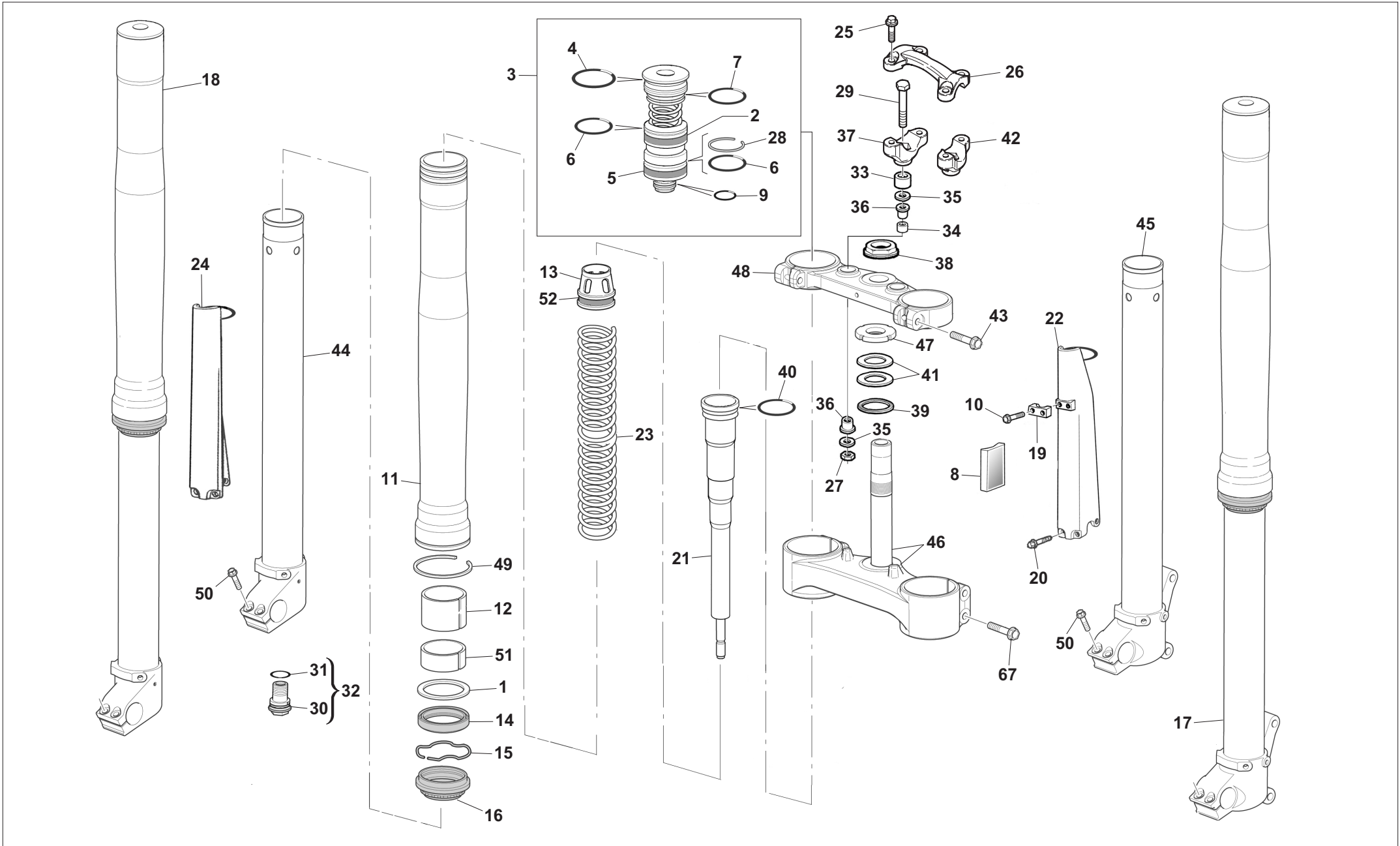

SOSPENSIONE ANTERIORE - FRONT FORK ASSEMBLY
SUSPENSION AVANT - VORDERTELESKOPGABEL
SUSPENSION DELANTERA

TAVOLA - DRAWING
TABLE - BILD - TABLA**15A**

Note Notes Notes Marke Notas	Pos. No. N. Index Pos.	N. Cod. Code No. Nr. Code Code Nr N. Cod.	Q.tà Q.ty Q.te M.ge C.ad	DENOMINAZIONE	NAME	DESIGNATION	BESHREIBUNG	DENOMINACION
	1	8000 H2661	2	Rosetta piana	Washer	Rondelle	Scheibe	Arandela
	2	8000 H2680	2	Segmento	Circlip	Segment	Kolbenring	Segmento
	3	8000 H2666	2	Valvola compressione compl.	Compression base valve assy	Clapet de pied compl.	Boden Ventil Komplett	Válvula de pie compl.
	4	8000 H2674	2	Anello OR	O-Ring	Bague OR	O Ring	Anillo OR
	5	8000 H2682	2	Segmento	Circlip	Segment	Kolbenring	Segmento
	6	8000 H2683	4	Anello OR	O-Ring	Bague OR	O Ring	Anillo OR
	7	8000 H2677	2	Anello OR	O-Ring	Bague OR	O Ring	Anillo OR
	8	8000 74842	2	Catadiottro ambra	Reflector amber	Catadioptrique ambre	Rückstrahler Amber	Catafaros àmbar
	9	8000 H2679	2	Anello OR	O-Ring	Bague OR	O Ring	Anillo OR
	10	8A00 84658	2	Vite	Screw	Vis	Schraube	Tornillo
	11	8000 H2656	2	Portastelo	Outer tube	Tuyau	Roh	Tubo
	12	8000 H2659	2	Bussola	Bushing	Douille	Buchse	Buje
	13	8000 H2668	2	Bussola	Bushing	Douille	Buchse	Buje
	14	8000 H2662	2	Anello di tenuta	Seal ring	Bague d'étancheite	Dichtring	Anillo de retención
	15	8000 H2663	2	Anello di fermo	Stop ring	Bague d'arrêt	Haltering	Anillo de retención
	16	8000 H2664	2	Raschiapolvere	Dust scraper	Racloir poudre	Pulverabschaber	Rascador de polvo
	17	8000 H2735	1	Gamba Sx completa	L.H. fork leg assy	Fourche compl. G.	Telegabel, Kpl. L.	Horquill izq. compl.
	18	8000 H2736	1	Gamba Dx completa	R.H. fork leg assy	Fourche complète D.	Telegabel Kpl. R.	Horquilla derech. compl.
	19	80A0 A0633	1	Piastrina	Plate	Plaque	Platte	Placa
	20	8000 A8423	6	Vite (M6x8 mm)	Screw (M6x8 mm)	Vis (M6x8 mm)	Schraube (M6x8 mm)	Tornillo (M6x8 mm)
	21	8000 H2665	2	Gruppo pompante compl.	Damping element compl.	Amortissement compl.	Schwingungsdämpfer Kpl.	Bombeadora compl.
	22	80A0 A8481	1	Protezione steli Sx NERO	Guard L.H. BLACK	Protection D. NOIR	Schutz L. SCHWARZ	Protección izq. NEGRO
	23	8000 H2669	2	Molla (K=4,2 N/mm)	Spring (K=4,2 N/mm)	Ressort (K=4,2 N/mm)	Feder (K=4,2 N/mm)	Resorte (K=4,2 N/mm)
	24	80A0 A8482	1	Protezione steli Dx NERO	Guard R.H. BLACK	Protection G. NOIR	Schutz R. SCHWARZ	Protección der. NEGRO
	25	8A00 B1959	4	Vite (M8x30 mm)	Screw (M8x30 mm)	Vis (M8x30 mm)	Schraube (M8x30 mm)	Tornillo (M8x30 mm)
	26	8000 H1358	1	Morsetto superiore	Hub	Moyeau	Radnabe	Cubo
	27	Z000 61314	2	Dado autobloccante	Nut	Mutter	Ecrou	Tuerca
	28	8000 H2681	2	Anello di fermo	Stop ring	Bague d'arrêt	Haltering	Anillo de retención
	29	60ND 01219	2	Vite (M10x65 mm)	Screw (M10x65 mm)	Vis (M10x65 mm)	Schraube (M10x65 mm)	Tornillo (M10x65 mm)
	30	8000 H2676	2	Mozzetto	Hub	Moyeau	Radnabe	Cubo
	31	8000 H2678	2	Anello OR	O-Ring	Bague OR	O Ring	Anillo OR
	32	8000 H2670	2	Registro estensione	Extention adjuster	Reglage	Gleitregister	Regulation extensión
	33	8A00 A6683	2	Distanziale	Spacer	Entretoise	Distanzstück	Separador

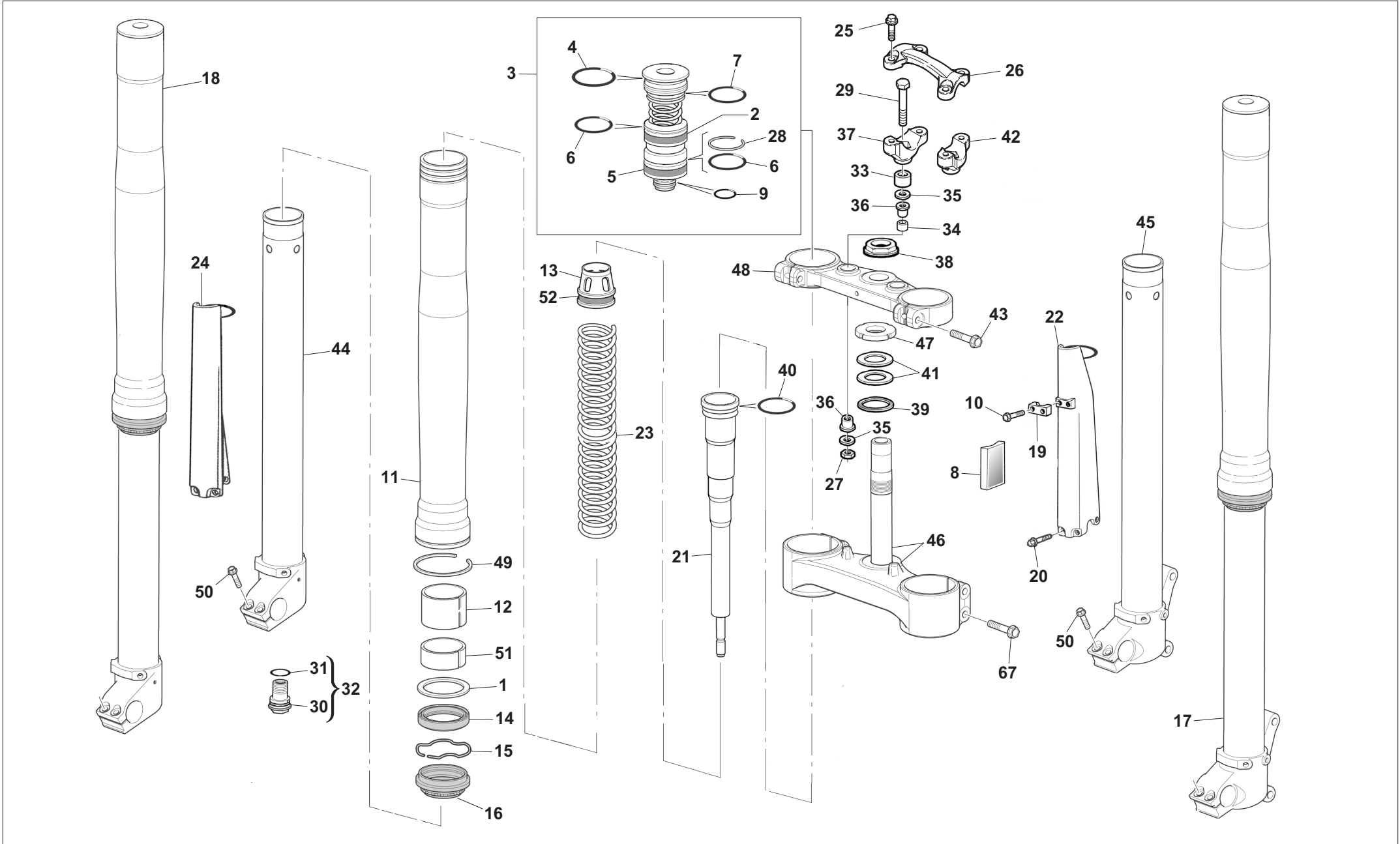

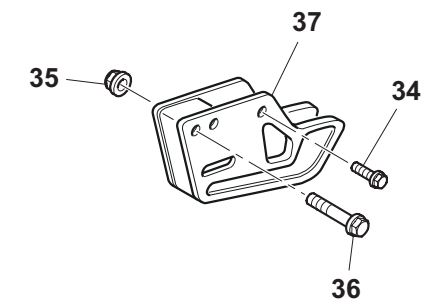
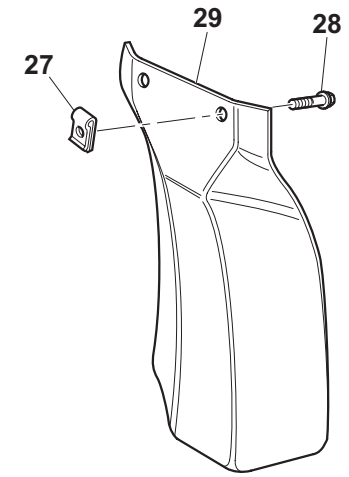
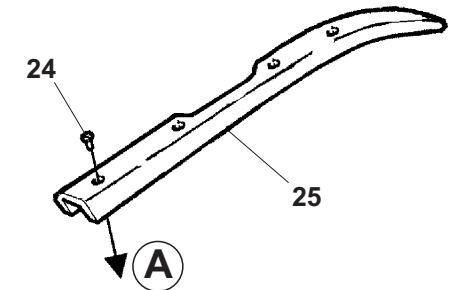
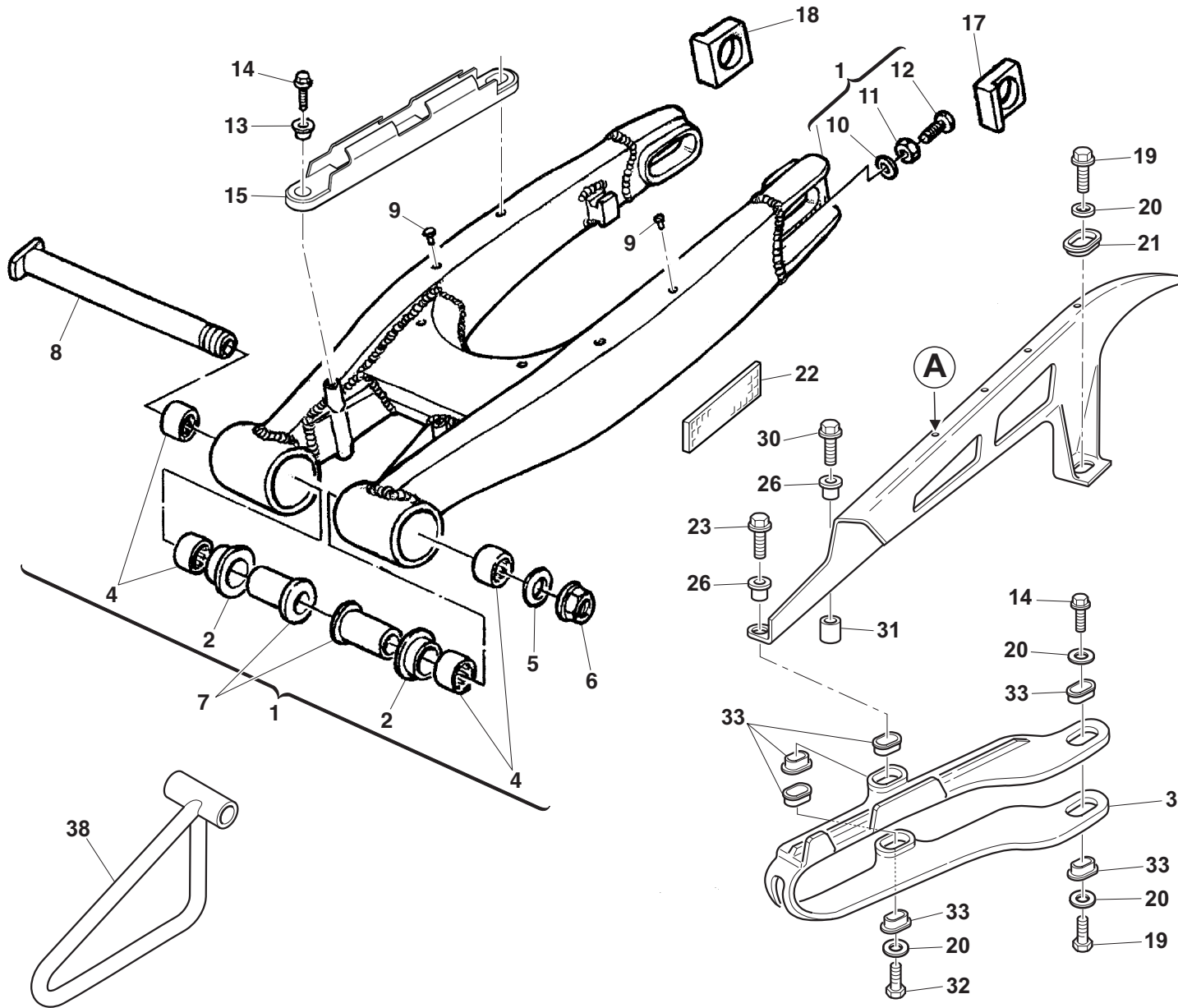

**FORCELLONE - SWING ARM
FOURCHE - GABEL
HORQUILLA**

Note Notes Notes Marke Notas	Pos. No. N. Index Pos.	N. Cod. Code No. Nr. Code Code Nr N. Cod.	Q.tà Q.ty Q.te M.ge C.ad	DENOMINAZIONE	NAME	DESIGNATION	BESHREIBUNG	DENOMINACION
	1	8000 H0680	1	Forcellone completo	Compl. fork	Fourche complete	Gabel, Kpl.	Horquilla compl.
	2	Z000 71622	2	Bussola	Bushing	Douille	Buchse	Buje
	3	8000 H1320	1	Pattino catena	Chain slider	Glissière de chaîne	Gleitbahn	Platode cadena
	4	8000 76283	4	Gabbia a rullini	Needle cage	Cage à aiguilles	Nadelkaefig	Jaula de agujas del cojinete
	5	8000 32388	1	Rosetta	Washer	Rondelle	Scheibe	Arandela
	6	Z000 71623	1	Dado	Nut	Ecrou	Mutter	Tuerca
	7	8000 71621	1	Bussola (L= 49,5 mm) Sx	Bushing (L= 49,5 mm) Left	Douille (L= 49,5 mm) Gouche	Buchse (L= 49,5 mm) SX	Buje (L= 49,5 mm) Izquierda
	7	8A00 71621	1	Bussola (L= 58,5 mm) Dx	Bushing (L= 58,5 mm) Right	Douille (L= 58,5 mm) Droite	Buchse (L= 58,5 mm) DX	Buje (L= 58,5 mm) Derecha
	8	8000 H1549	1	Perno forcellone	Fork pin	Pivot fourche	Gabelbolzen	Perno horquilla
C	9	8000 75160	7	Rivetto	Rivet	Rivet	Niet	Remache
W	9	8000 75160	5	Rivetto	Rivet	Rivet	Niet	Remache
	10	Z000 08536	2	Rosetta	Washer	Rondelle	Scheibe	Arandela
	11	Z000 17810	2	Dado	Nut	Ecrou	Mutter	Tuerca
	12	ZC00 61121	2	Vite	Screw	Vis	Schraube	Tornillo
	13	8000 69282	2	Bussola	Bushing	Douille	Buchse	Buje
	14	Z000 20536	2	Vite	Screw	Vis	Schraube	Tornillo
	15	8000 B1166	1	Guida tubo	Guide ring	Bague de guide	Rohrring	Guía-cable
W	16	8AB0 73909	1	Copricatena	Chain guard	Carter de chaîne	Kettenkasten	Cubre-cadena
	17	8000 96941	1	Tendicatena Sx	Chain adjuster Left	Tendeur de chaîne Gouche	Kettenspanne L.	Tensor de cadena Izquierda
	18	8000 96944	1	Tendicatena DX	Chain adjuster Right	Tendeur de chaîne Droite	Kettenspanner R.	Tensor de cadena Derecha
	19	Z000 20536	3	Vite	Screw	Vis	Schraube	Tornillo
	20	Z000 36137	4	Rosetta	Washer	Rondelle	Scheibe	Arandela
C	21	8000 59289	6	Scodellino	Cup	Couvette	Teller	Cubeta
CU	22	8000 73832	2	Catadiottro	Reflector	Catadioptrique	Rückstrahler	Catafaros
C	23	Z000 67997	2	Vite (M5x12 mm)	Screw (M5x12 mm)	Vis (M5x12 mm)	Schraube (M5x12 mm)	Tornillo (M5x12 mm)
W	23	ZA00 67997	2	Vite (M5x16 mm)	Screw (M5x16 mm)	Vis (M5x16 mm)	Schraube (M5x16 mm)	Tornillo (M5x16 mm)
W	24	8000 81628	4	Vite	Screw	Vis	Schraube	Tornillo
W	25	8000 A2352	1	Prolunga per copricatena	Chain guard extension	Carter de chaîne extension	Kettenkastenverlängerung	Prolonga por cubre-cadena
W	26	8A00 69282	2	Bussola	Bushing	Douille	Buchse	Buje
	27	U000 55134	2	Dado a graffetta	Nut	Ecrou	Mutter	Tuerca
	28	8A00 A8421	2	Vite	Screw	Vis	Schraube	Tornillo
	29	8000 69551	1	Protezione ammortizzatore	Guard	Protection	Schutz	Protección
W	30	ZC00 67997	1	Vite (M5x35 mm)	Screw (M5x35 mm)	Vis (M5x35 mm)	Schraube (M5x35 mm)	Tornillo (M5x35 mm)



TAVOLA 16B
DRAWING 16B
TABLE 16B
BILD 16B
TABLA 16B



WR 125/2013
CR 125/2013

TAVOLA - DRAWING
TABLE - BILD - TABLA

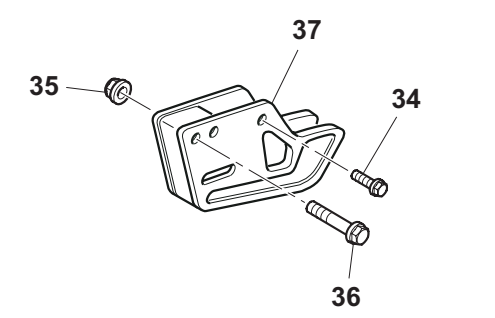
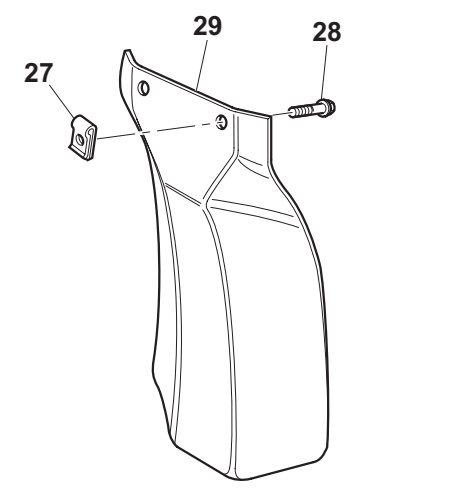
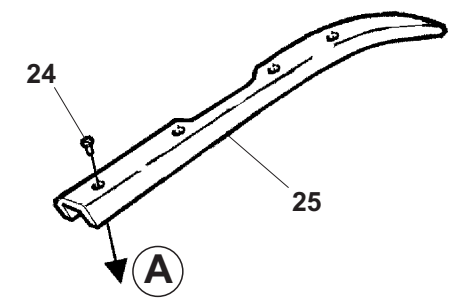
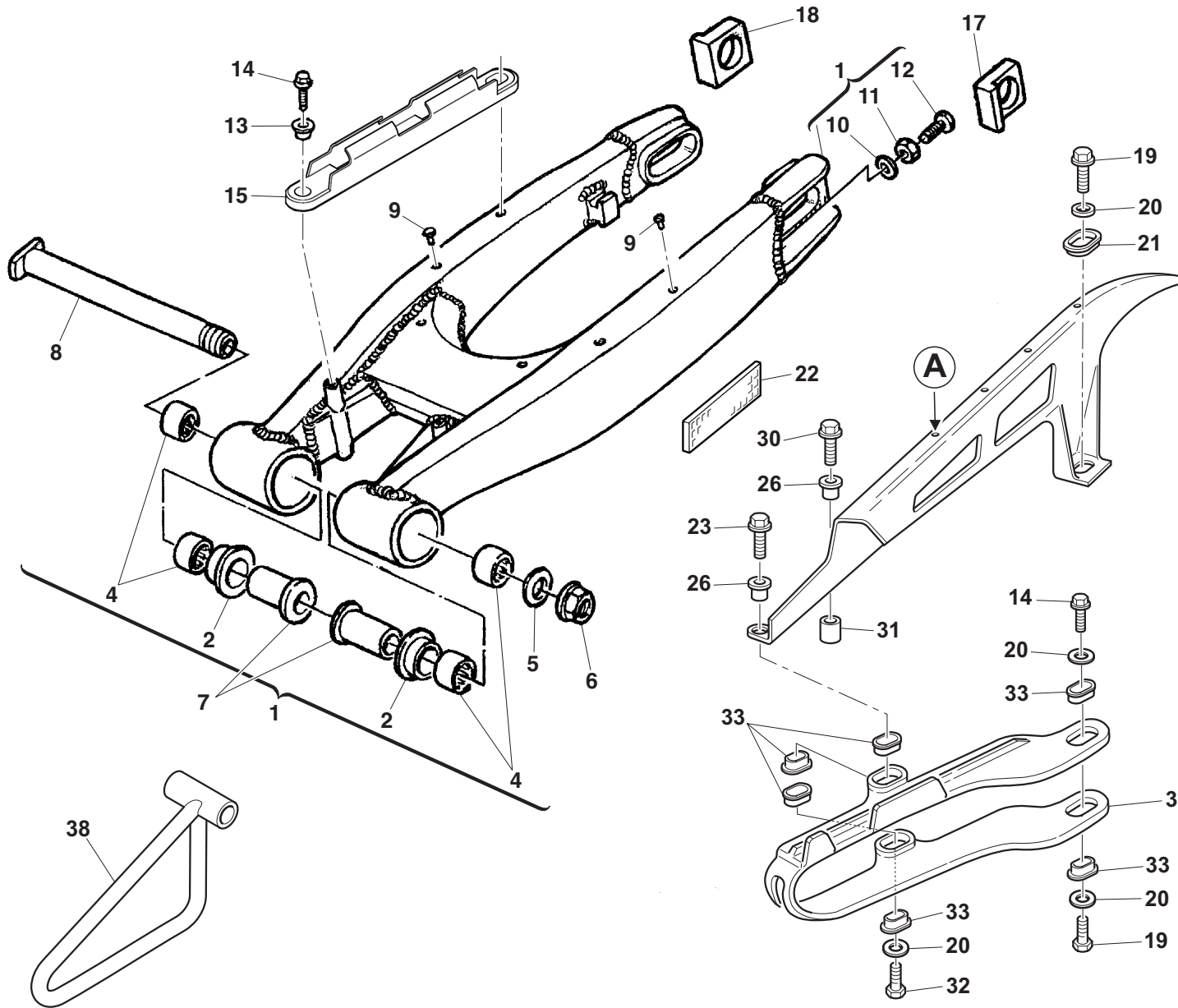
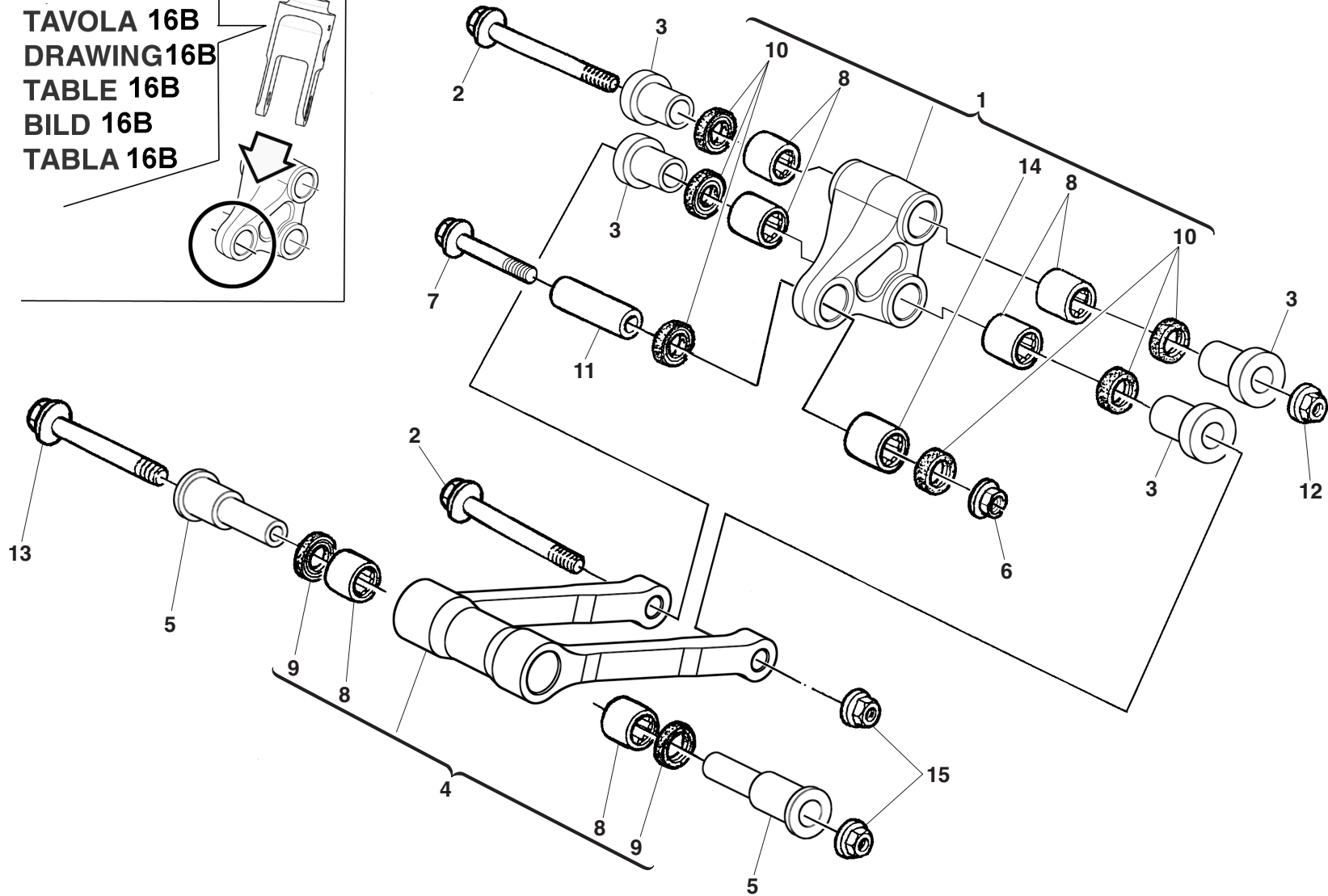
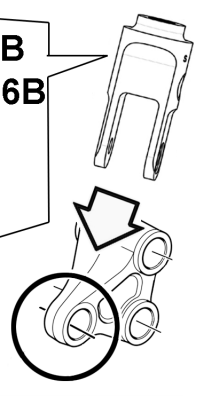
16A

LEVERAGGI SOSPENSIONE POSTERIORE - REAR SUSPENSION LINKAGE
LEVIER SUSPENSION ARRIERE - HEBELWERK HINTERHAUFHANGUNG
PALANCA SUSPENSION TRASERA



Note Notes Notes Marke Notas	Pos. No. Index Pos.	N. Cod. Code No. Nr. Code Code Nr N. Cod.	Q.tà Q.ty Q.te M.ge C.ad.	DENOMINAZIONE	NAME	DESIGNATION	BESHREIBUNG	DENOMINACION
	1	8000 B0239	1	Assieme bilanciare	Rocking lever assy	Balancier compl.	Schwinge Kpl.	Balancines compl.
	2	YA00 B0240	2	Vite (M12x103 mm)	Screw (M12x103 mm)	Vis (M12x103 mm)	Schraube (M12x103 mm)	Tornillo (M12x103 mm)
	3	8000 B0288	4	Spinotto	Gudgeon	Axe	Bolzen	Perno
	4	8000 B0236	1	Tirante completo	Tie rod	Tirant	Spannstange	Tirante
	5	8000 B0241	2	Spinotto	Gudgeon	Axe	Bolzen	Perno
	6	Z000 42022	1	Dado	Nut	Ecrou	Mutter	Tuerca
	7	ZD00 62797	1	Vite (M10x47 mm)	Screw (M10x47 mm)	Vis (M10x47 mm)	Schraube (M10x47 mm)	Tornillo (M10x47 mm)
	8	8000 42781	6	Cuscinetto	Bearing	Roulement	Kugellager	Cojinete
	9	8000 32065	2	Anello di tenuta	Seal ring	Bague de retenue	Dichtring	Anillo de retención
	10	8000 32065	6	Anello di tenuta	Seal ring	Bague de retenue	Dichtring	Anillo de retención
	11	8000 A4431	1	Spinotto D20-d10-L25,2	Gudgeon D20-d10-L25,2	Axe D20-d10-L25,2	Bolzen D20-d10-L25,2	Perno D20-d10-L25,2
	12	Z000 42023	3	Dado	Nut	Ecrou	Mutter	Tuerca
	13	Y000 B0240	1	Vite (M12x122 mm)	Screw (M12x122 mm)	Vis (M12x122 mm)	Schraube (M12x122 mm)	Tornillo (M12x122 mm)
	14	8000 32064	1	Cuscinetto	Bearing	Roulement	Kugellager	Cojinete
	15	Z000 17810	2	Dado	Nut	Ecrou	Mutter	Tuerca

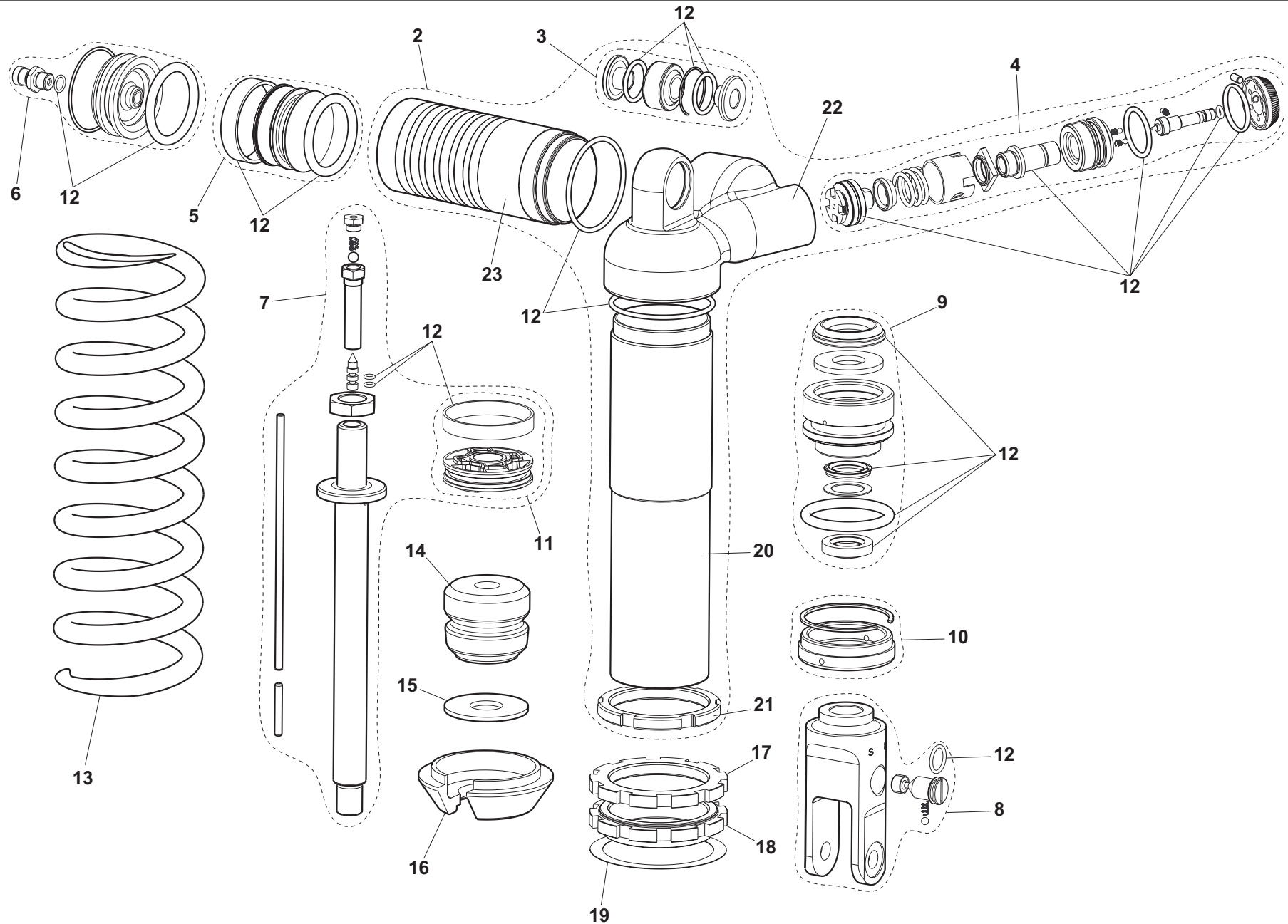

WR 125/2013
CR 125/2013

TAVOLA - DRAWING
TABLE - BILD - TABLA

16B

AMMORTIZZATORE POSTERIORE - REAR SHOCK ABSORBER
AMMORTISSEUR ARRIERE - HINTERSTOSSDAMPFER
AMORTIGUADOR TRASERO



Note Notes Notes Marke Notas	Pos. No. N. Index Pos.	N. Cod. Code No. Nr. Code Code Nr N. Cod.	Q.tà Q.ty Q.te M.ge C.ad	DENOMINAZIONE	NAME	DESIGNATION	BESHREIBUNG	DENOMINACION
C	1	8000 H1574	1	Ammortizzatore completo	Shock-absorber assy	Ammortisseur compl.	Stossdampfer Kpl.	Amortigüador compl.
W	1	8000 H1591	1	Ammortizzatore completo	Shock-absorber assy	Ammortisseur compl.	Stossdampfer Kpl.	Amortigüador compl.
	2	8000 H3630	1	Gruppo corpo	Damper case assy	Groupe corps amortisseur	Stossdämpferkörper Kpl.	Corpo amortigüador compl.
	3	8000 89089	1	Gruppo snodo	Ball joint assy	Groupe joint a rotule	Kugelgelenkgruppe Kpl.	Grupo articulaciòn esférica
	4	8000 B1922	1	Gruppo regolazione	Adjuster set	Groupe réglage	Reglergruppe Kpl.	Grupo regulaciòn
	5	8000 A5071	1	Diaframma	Diaphragm	Diaphragme	Biegeplatte	Diafragma
	6	8000 98491	1	Gruppo tappo	Plug assy.	Groupe bouchon	Verschlussgruppe Kpl.	Grupo tapòn
C	7	8000 H3631	1	Gruppo stelo	Rod assy	Groupe tige	Pumpenstückgruppe	Grupo espiga
W	7	8000 H3641	1	Gruppo stelo	Rod assy	Groupe tige	Pumpenstückgruppe	Grupo espiga
	8	8000 H0071	1	Gruppo forcella	Fork assy	Groupe fourche	Gabelgruppe Kpl.	Grupo horquilla
	9	8000 H1051	1	Gruppo guida stelo	Guide rod assy	Groupe guide tige	Pumpenstückführungsgruppe	Grupo guja espiga
	10	8000 H1055	1	Gruppo tappo ammortizzatore	Shock-absorber plug assy	Groupe bouchon amortisseur	Verschlussgruppe Kpl.	Grupo tapòn amortigüador
	11	8000 H1056	1	Gruppo pistone + segmento	Piston assy + segment	Groupe piston + segment	Kolben Kpl. + kolbenring	Grupo pistòn + segmento
	12	8000 H3634	1	Gruppo guarnizioni	Gasket set	Groupe garnitures	Dichtungssatz	Grupo juntas
	13	8000 98568	1	Molla	Spring	Ressort	Feder	Resorte
	14	8000 A6670	1	Tampone	Pad	Tampon	Stopfen	Tampòn
	15	8000 H0077	1	Rosetta	Washer	Rondelle	Scheibe	Arandela
	16	8000 98496	1	Fondello	Bottom	Fond	Bodenscheibe	Casquillo
	17	8000 98498	1	Controghiera	Ring nut	Embout	Nutmutter	Virola
	18	8000 98497	1	Ghiera	Ring nut	Embout	Nutmutter	Virola
	19	8000 98499	1	Rosetta per molla	Washer	Rondelle	Scheibe	Arandela
	20	8000 H0074	1	Corpo ammortizzatore	Damper case	Corps amortisseur	Stossdämpferkörper	Corpo amortigüador
	21	8000 B1923	1	Ghiera	Ring nut	Embout	Nutmutter	Virola
	22	8000 H3636	1	Basetta	Side	Base	Platte	Placa
	23	8000 H3637	1	Serbatoio	Tank	Réservoir	Tank	Depósito

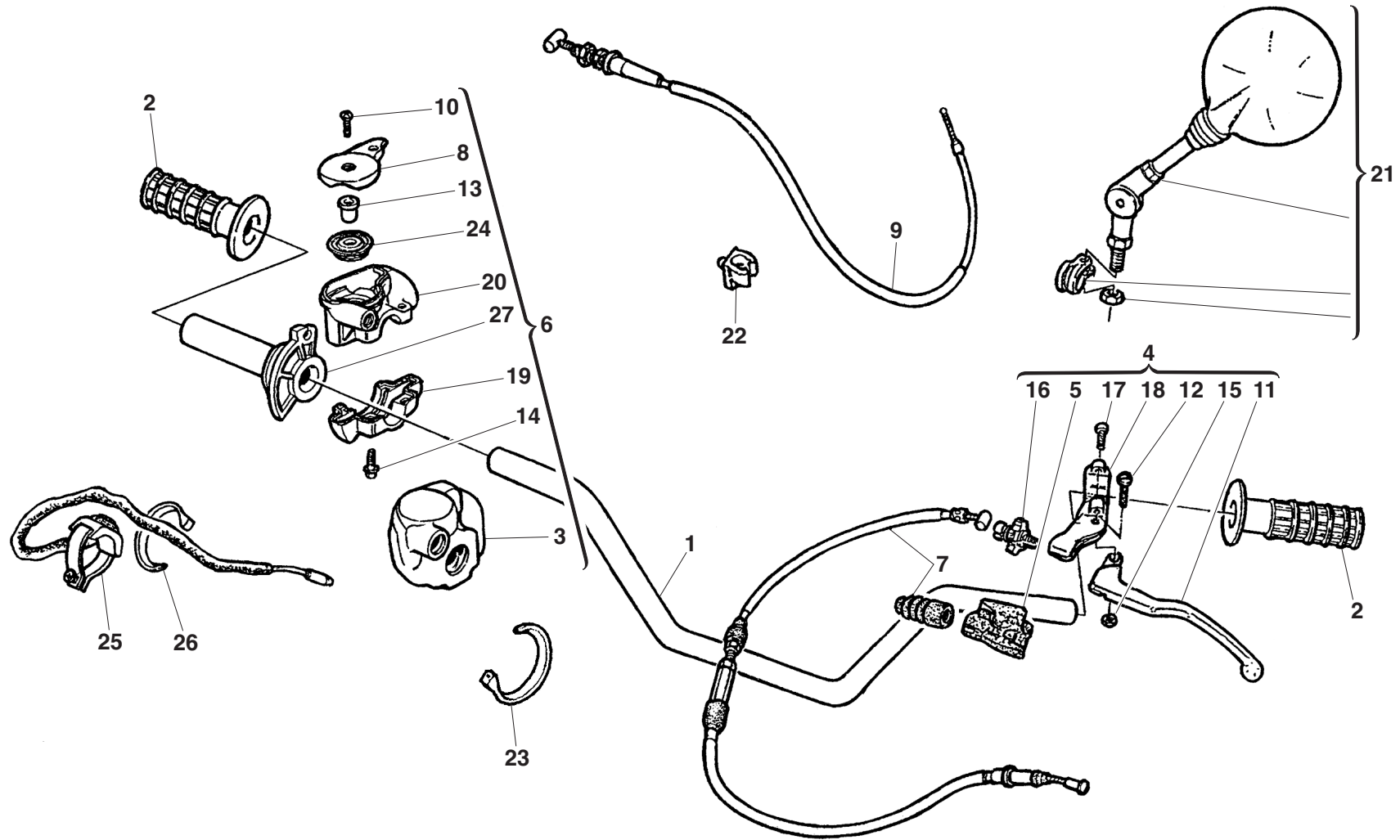

MANUBRIO E COMANDI - HANDLEBAR AND CONTROLS
GUIDON ET COMMANDES - LENKER UND STEUERORGANE
MANILLAR Y MANDOS

Note Notes Notes Marke Notas	Pos. No. N. Index Pos.	N. Cod. Code No. Nr. Code Code Nr N. Cod.	Q.tà Q.ty Q.te M.ge C.ad	DENOMINAZIONE	NAME	DESIGNATION	BESHREIBUNG	DENOMINACION
	1	8000 H6609	1	Manubrio	Hanblebar	Guidon	Lenker	Manillar
	2	8000 H6049	1	Manopole	Grip	Poignée	Griff	Manopla
	3	8000 93752	1	Gommino coprigas	Rubber cover	Coverture caoutchouc	Gummistück	Goma
CU	4	8000 75330	1	Comando frizione completo	Clutch control assy	Commande embrayage compl.	Führungssteuerung	Mando embrague compl.
W	4	8000 H4513	1	Comando frizione completo	Clutch control assy	Commande embrayage compl.	Führungssteuerung	Mando embrague compl.
	5	8000 48917	1	Coprileva	Lever cover	Couvre levier	Hebeldeckel	Cubre-palanca
	6	8000 88865	1	Comando gas completo	Throttle control compl.	Commande gaz compl.	Gasgriff kpl.	Accionamiento acelerador compl.
	7	8000 H0128	1	Trasm. comando frizione	Clutch transmission	Transm. com. embrayage	Führungssteuerung	Trans. mando embrague com.
	8	8000 93751	1	Coperchietto	Cover	Couvercle	Deckel	Tapa
	9	8000 H0129	1	Trasmissione gas	Throttle trasm.	Trasm. comm. gaz	Führungssteuerung des Gases	Tran.mando acelerador compl.
	10	8000 50798	2	Vite	Screw	Vis	Schraube	Tornillo
	11	8000 77737	1	Leva comando frizione	Clutch lever	Levier embrayage	Kupplungshebel	Palanca mando embrague
	12	8000 38797	1	Vite	Screw	Vis	Schraube	Tornillo
	13	8000 93750	1	Bussola	Bushing	Douille	Buchse	Buje
	14	8000 62728	2	Vite	Screw	Vis	Schraube	Tornillo
	15	8000 87812	1	Dado	Nut	Ecrou	Mutter	Tuerca
	16	8000 48916	1	Gruppo registro	Adjuster set	Groupe reglage	Kupplungsreglergruppe	Grupo regulaciòn
	17	8000 62728	2	Vite	Screw	Vis	Schraube	Tornillo
CU	18	8000 70698	1	Cavallotto	U-bolt	Cavalier	Bügelbolzen	Caballete
W	18	8000 H6328	1	Cavallotto	U-bolt	Cavalier	Bügelbolzen	Caballete
	19	8000 93747	1	Supporto inferiore	Lower support	Support inférieur	Untere Halterung	Soporte inferiør
	20	8000 93746	1	Supporto superiore	Upper support	Support supérieur	Obere Halterung	Soporte superiør
XD	21	8000 H1673	1	Specchietto retrov. Dx	R.H. Driving mirror	Rétroviseur D.	R. Rückspiegel	Espejo retrovisor Der.
XD	21	8A00 H1673	1	Specchietto retrov. Sx	L.H. Driving mirror	Rétroviseur G.	L. Rückspiegel	Espejo retrovisor Izq.
	22	80A0 58207	2	Molletta	Tube clip	Ressort	Feder	Resorte
	23	8000 56444	5	Fascetta	Clamp	Collier	Schelle	Banda
DW	24	8000 93749	1	Carrucola	Pulley	Poulie	Führungsrolle	Polea
CU	25	8000 96828	1	Pulsante ENGINE STOP	ENGINE STOP button	Bouton ENGINE STOP	Knopfaste ENGINE STOP	Pulsador ENGINE STOP
CU	26	8000 71578	1	Fascetta	Clamp	Collier	Schelle	Banda
	27	8000 93748	1	Tubo comando gas	Throttle pipe	Tuyau gaz	Gasrohr	Tubo aceleradør

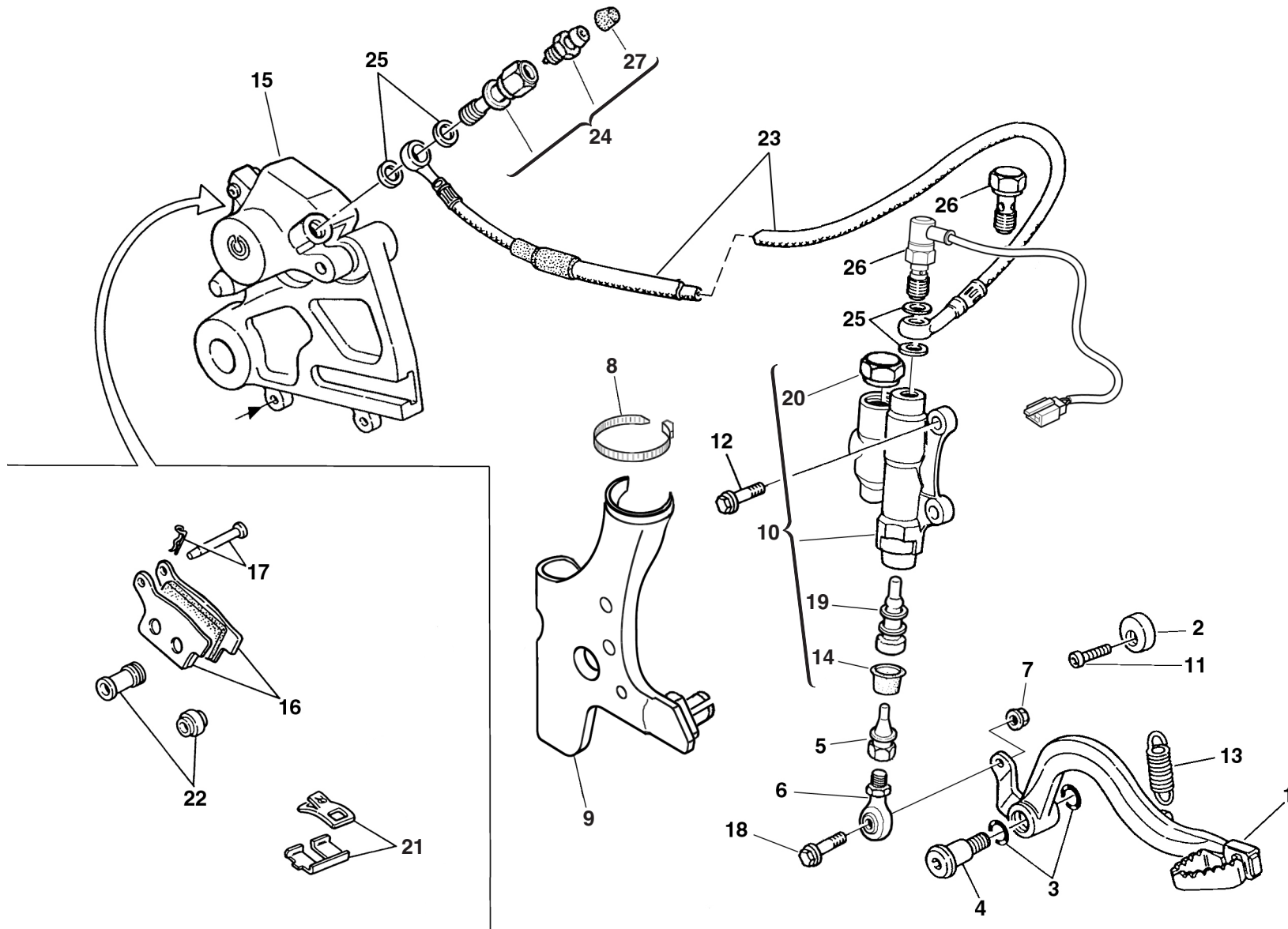

FRENO IDRAULICO POSTERIORE - REAR HYDRAULIC BRAKE
FREIN HYDRAULIQUE ARRIERE - HINTERBREMSE
FRENO HIDRAULICO TRASERO

Note Notes Notes Marke Notas	Pos. No. N. Index Pos.	N. Cod. Code No. Nr. Code Code Nr N. Cod.	Q.tà Q.ty Q.te M.ge C.ad	DENOMINAZIONE	NAME	DESIGNATION	BESHREIBUNG	DENOMINACION
	1	8000 A7634	1	Pedale comando freno	Brake control pedal	Pedal comm. frein	Bremspedal	Pedal accionamiento freno
	2	8A00 69125	1	Camma	Cam	Came	Nocken	Exéntrico
	3	8000 22551	2	Anello OR	O-Ring	Bague OR	O Ring	Anillo OR
	4	Y000 55902	1	Vite	Screw	Vis	Schraube	Tornillo
	5	8000 A7635	1	Puntalino	Push rod	Embout	Stösselschaft	Puntàl
	6	8A00 76055	1	Snodo sferico	Ball joint	Joint a rotule	Kugelgelenk	Articulación esférica
A	6	7640 10002	1	Snodo sferico Dx	Ball joint Right	Joint a rotule Droite	Kugelgelenk R.	Articulación esférica Derecha
	7	61ND 15062	1	Dado	Nut	Ecrou	Mutter	Tuerca
	8	8000 56444	1	Fascetta (L=188mm)	Clamp (L=188mm)	Collier (L=188mm)	Schelle (L=188mm)	Banda (L=188mm)
	9	8000 H3434	1	Protezione telaio Dx	R.H. frame guard	Protection chassis D.	Rahmenschutz Rechts	Protección bastidor derecha
	10	8000 A7633	1	Pompa comando freno	Brake pump assy	Pompe frein complet	Bremspumpe kl.	Bomba freno compl.
	11	Y000 55241	1	Vite	Screw	Vis	Schraube	Tornillo
	12	Z000 62726	2	Vite	Screw	Vis	Schraube	Tornillo
	13	8000 H5148	1	Molla	Spring	Ressort	Feder	Resorte
	14	8000 A9449	1	Cuffia	Boots	Poussiers	Haube	Gorro
	15	8000 A4291	1	Pinza freno completa	Brake caliper assy	Pince de frein, compl.	Bremszange, Kpl.	Pinza freno compl.
	16	8000 A2790	1	Coppia pastiglie	Pads pair	Paire plaquettes	Bremsbelagpaar	Pareja pastillas
	17	8000 A2791	1	Perno	Pin	Pivot	Bolzen	Perno
	18	8000 62727	1	Vite	Screw	Vis	Schraube	Tornillo
	19	8000 A9448	1	Flottante	Plunger	Piston	Kolben	Pistón
	20	8000 A9447	1	Tappo	Plug	Bouchon	Verschluss	Tapón
	21	8000 A2792	1	Molla-lamierino	Spring-steel clip	Ressort	Feder	Rresorte
	22	8000 79066	1	Cuffie	Boots	Poussiers	Haube	Gorro
	23	8000 H0821	1	Tubo mandata olio	Oil pipe	Tuyauterie d'huile	Oelrohr	Tubo aceite
	24	8000 A3975	1	Bocchettone spurgo completo	Bleeding union pipe	Goulotte révision curage	Reinigungstutzen	Boca de purga
	25	8000 90485	4	Rosetta	Washer	Rondelle	Scheibe	Arandela
C	26	U000 57155	1	Vite	Screw	Vis	Schraube	Tornillo
W	26	8000 94849	1	Interruttore stop posteriore	Stop switch	Interrupteur stop	Stopschalter	Interruptor stop trasero
	27	8000 53259	1	Parapolvere	Boots	Para-poudr	Schutzhaube	Para-polvo

PANNELLI, PARAFANGHI, SELLA - PANEL, FENDERS, SEAT
PANNEAU, GARDE-BOUES, SIEGE - STREIFEN, KOTFLUGEL, SATTEL
PANELO, GUARDABARROS, SILLIN

Note Notes Notes Marke Notas	Pos. No. Index Pos.	N. Cod. Code No. Nr. Code Code Nr N. Cod.	Q.tà Q.ty Q.te M.ge C.ad	DENOMINAZIONE	NAME	DESIGNATION	BESHREIBUNG	DENOMINACION
	1	8000 B0170	1	Sella	Seat	Siège	Sattel	Sillín
CU	2	80C0 A4216	1	Portanumero	Front number holder	Portenumero	Schlüsselring	Portanumero
W	3	80C0 H0198	1	Cupolino	Front fairing	Carenage avant	Vord. Verkleidung	Cúpula delantera
	4	8A00 A8421	1	Vite (M5x12 mm)	Screw (M5x12 mm)	Vis (M5x12 mm)	Schraube (M5x12 mm)	Tornillo (M5x12 mm)
WD	5	U000 55134	1	Dado a graffetta	Nut	Ecrou	Mutter	Tuerca
	6	80A0 A4198	1	Rinforzo per parafango	Fender holder	Soutie pour garde-boue	Kotfluegelsupport	Soporte por guardabarros del.
	7	8000 69149	1	Rosetta	Washer	Rondelle	Scheibe	Arandela
	8	Z000 65535	2	Vite	Screw	Vis	Schraube	Tornillo
	9	8538649	1	Pannello destro	R.H. panel	Panneau, D.	Streifen. R.	Panel Derecho
	10	8538648	1	Pannello sinistro	L.H. panel	Panneau, G.	Streifen. L.	Panel izquierdo
	11	8B00 A8421	4	Vite	Screw	Vis	Schraube	Tornillo
C	12	80C0 H0294	1	Parafango posteriore	Rear fender	Garde-boue arrière	Hint. Kotfluegel	Guarda-barros trasero
W	12	80C0 H1592	1	Parafango posteriore BIANCO	Rear mudguard WHITE	Garde-boue arrière BLANC	Hint. Kotfluegel WEISS	Guarda-barros trasero BLANCO
	13	Z000 61355	2	Dado	Nut	Ecrou	Mutter	Tuerca
C	14	8000 62729	4	Vite	Screw	Vis	Schraube	Tornillo
W	14	Z000 62729	4	Vite	Screw	Vis	Schraube	Tornillo
	15	8000 H1917	1	Perno	Pin	Pivot	Bolzen	Perno
	16	80C0 H0878	1	Parafango anteriore BIANCO	Front fender	Garde-boue avant	Vord. Kotfluegel	Guarda-barros delantero
WD	17	8000 56444	3	Fascetta (L=188mm)	Clamp (L=188mm)	Collier (L=188mm)	Schelle (L=188mm)	Banda (L=188mm)
C	18	8000 A8423	2	Vite	Screw	Vis	Schraube	Tornillo
C	19	8B00 A8423	2	Vite	Screw	Vis	Schraube	Tornillo
	20	8000 H3006	1	Attacco portanumero	Spacer	Entretoise	Distanzstück	Separador
	21	ZC00 69429	4	Bussola	Bushing	Douille	Buchse	Buje
	22	8000 72494	1	Molletta	Tube clip	Ressort	Feder	Resorte
	23	Z000 48814	4	Rosetta	Washer	Rondelle	Scheibe	Arandela
	24	Z000 62727	2	Vite (M6x16 mm)	Screw (M6x16 mm)	Vis (M6x16 mm)	Schraube (M6x16 mm)	Tornillo (M6x16 mm)
CU	25	8000 A4609	1	Piastrina	Plate	Plaque	Platte	Placa
CU	26	8000 69429	1	Bussola	Bushing	Douille	Buchse	Buje
CU	27	ZE00 67997	1	Vite	Screw	Vis	Schraube	Tornillo
CU	28	8000 46893	1	Dado	Nut	Ecrou	Mutter	Tuerca
CU	29	Z000 62726	1	Vite	Screw	Vis	Schraube	Tornillo
CU	30	Z000 62728	1	Vite	Screw	Vis	Schraube	Tornillo
CU	31	80A0 A4610	1	Guidafilo	Cable guide	Passe-câble	Kabelführung	Prensa-cable

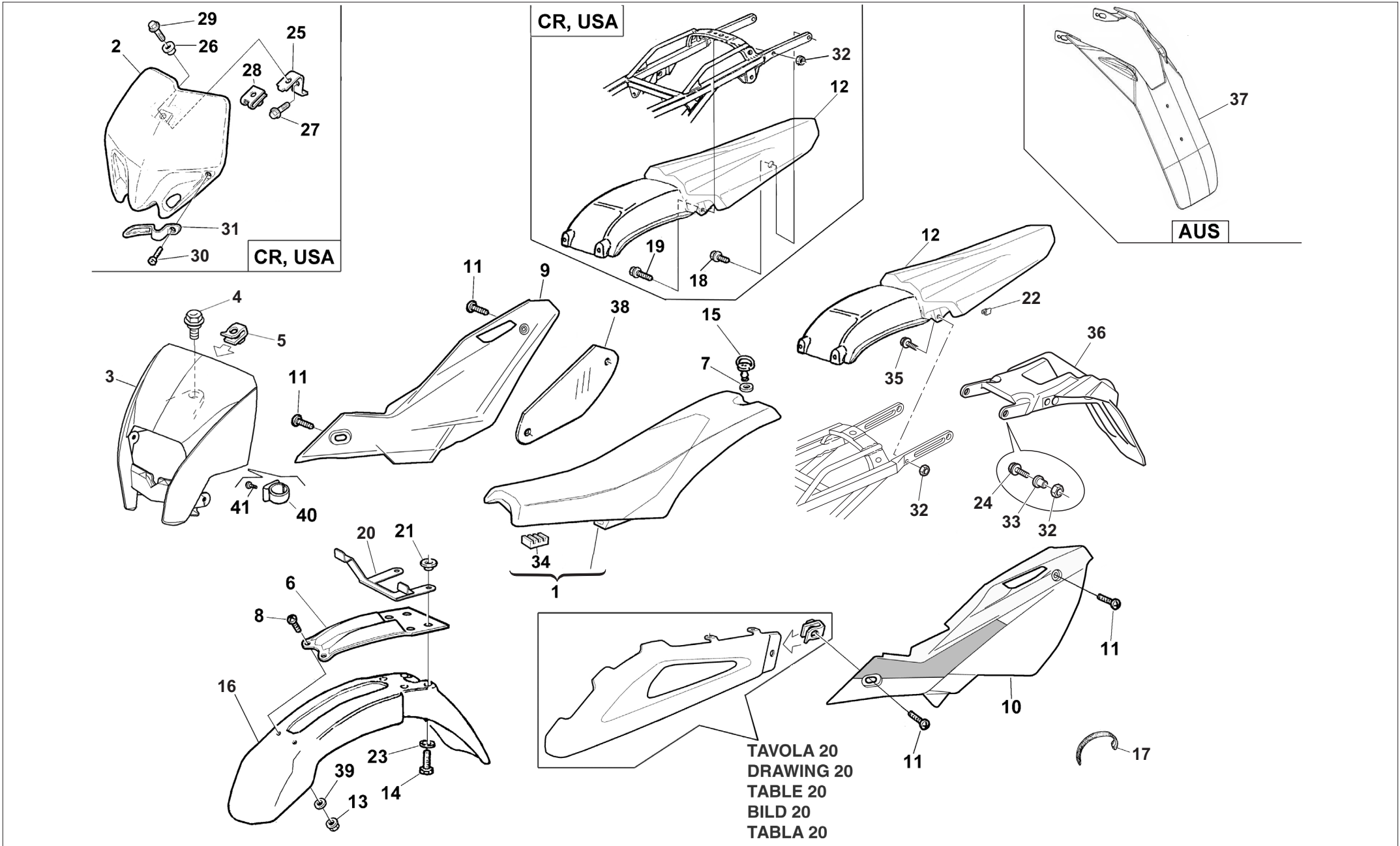



TAVOLA 19
DRAWING 19
TABLE 19
BILD 19
TABLA 19

SERBATOIO CARBURANTE, CONVOGLIATORI - GAS TANK, PANEL -
RESERVOIR CARBURANT, FLANC - KRAFTSTOFFBEHALTER, FLANKE -
DEPOSITO GASOLINA, LATERAL

Note Notes Notes Marke Notas	Pos. No. N. Index Pos.	N. Cod. Code No. Nr. Code Code Nr N. Cod.	Q.tà Q.ty Q.te M.ge C.ad	DENOMINAZIONE	NAME	DESIGNATION	BESHREIBUNG	DENOMINACION
CU	1	8000 H0056	1	Serbatoio carburante	Fuel tank	Réservoir essence	Kraftstoffbehälter	Depósito gasolina
W	1	8000 H2201	1	Serbatoio carburante	Fuel tank	Réservoir essence	Kraftstoffbehälter	Depósito gasolina
	2	8000 A8421	2	Vite flangiata (M5x8 mm)	Flange bolt (M5x8 mm)	Boulon de bride (M5x8 mm)	Flanschschraube (M5x8 mm)	Perno de reborde (M5x8 mm)
	3	8000 B1057	1	Tappo serbatoio	Tank cap	Bouchon reservoir	Behälterstöpsel	Tapón depósito
	4	8000 A4562	1	Guarnizione	Gasket	Garniture	Dichtung	Junta
CU	5	8000 67440	1	Rubinetto benzina	Fuel cock	Robinet de combustible	Kraftstoffhahn	Llave de paso gasolina
W	5	8000 43592	1	Rubinetto benzina	Fuel cock	Robinet de combustible	Kraftstoffhahn	Llave de paso gasolina
CU	6	8000 A8278	1	Anello OR	O-Ring	Bague OR	O Ring	Anillo OR
W	6	8000 01199	1	Anello OR	O-Ring	Bague OR	O Ring	Anillo OR
	7	60ND 04134	1	Vite (M6x20 mm)	Screw (M6x20 mm)	Vis (M6x20 mm)	Schraube (M6x20 mm)	Tornillo (M6x20 mm)
	8	8000 66238	1	Distanziale	Spacer	Entretoise	Distanzstück	Separador
	9	8000 45495	6	Boccola	Bushing	Douille	Buchse	Manguito
	10	Z000 37745	2	Vite	Screw	Vis	Schraube	Tornillo
	11	U000 55134	2	Dado a graffetta	Nut	Ecrou	Mutter	Tuerca
	12	9472 00035	1	Tubo	Pipe	Tuyau	Rohr	Tubo
	13	60ND 07335	1	Vite	Screw	Vis	Schraube	Tornillo
	14	8000 A5678	1	Rosetta	Washer	Rondelle	Scheibe	Arandela
	15	8000 36467	4	Vite (M6x10 mm)	Screw (M6x10 mm)	Vis (M6x10 mm)	Schraube (M6x10 mm)	Tornillo (M6x10 mm)
	16	80A0 42349	2	Fascetta	Clamp	Collier	Schelle	Banda
CU	17	8000 67700	1	Filtro	Filter	Filtre	Filter	Filtro
W	17	8000 38748	1	Filtro	Filter	Filtre	Filter	Filtro
	18	8A00 A8421	4	Vite	Screw	Vis	Schraube	Tornillo
	19	8000 B0647	2	Tampone	Pad	Tampon	Stopfen	Tampón
	20	9472 00043	1	Condotto benzina (L=200mm)	Pipe (L=200mm)	Tuyau (L=200mm)	Rohr (L=200mm)	Tubo (L=200mm)
	21	8000 37745	2	Vite	Screw	Vis	Schraube	Tornillo
	22	8538414	1	Convogliatore Dx	R. side panel	Flanc D.	Flanke R.	Lateral D.
	23	8538415	1	Convogliatore Sx	L. side panel	Flanc G.	Flanke L.	Lateral I.
	24	8000 H0256	1	Protezione Dx	R.H. protection	Protection D.	Schutz Rechte	Protección der.
	25	8000 H0255	1	Protezione Sx	L.H. protection	Protection G.	Schutz Linke	Protección izquierda
	26	Z000 37745	2	Vite	Screw	Vis	Schraube	Tornillo
	27	8B00 A0680	2	Distanziale	Spacer	Entretoise	Distanzstück	Separador
	28	8000 61362	1	Rosetta	Washer	Rondelle	Scheibe	Arandela
	29	8A00 61362	1	Rosetta	Washer	Rondelle	Scheibe	Arandela



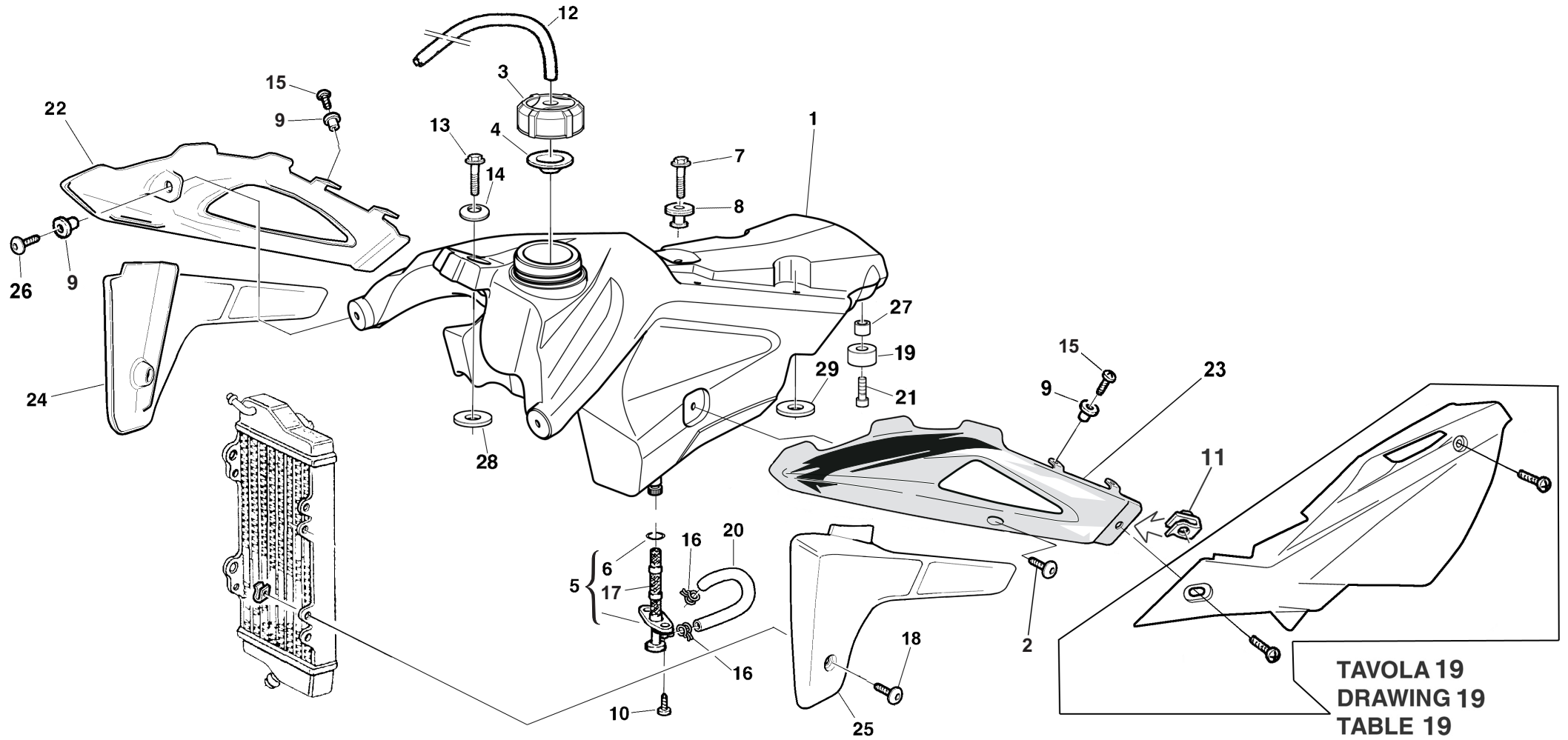
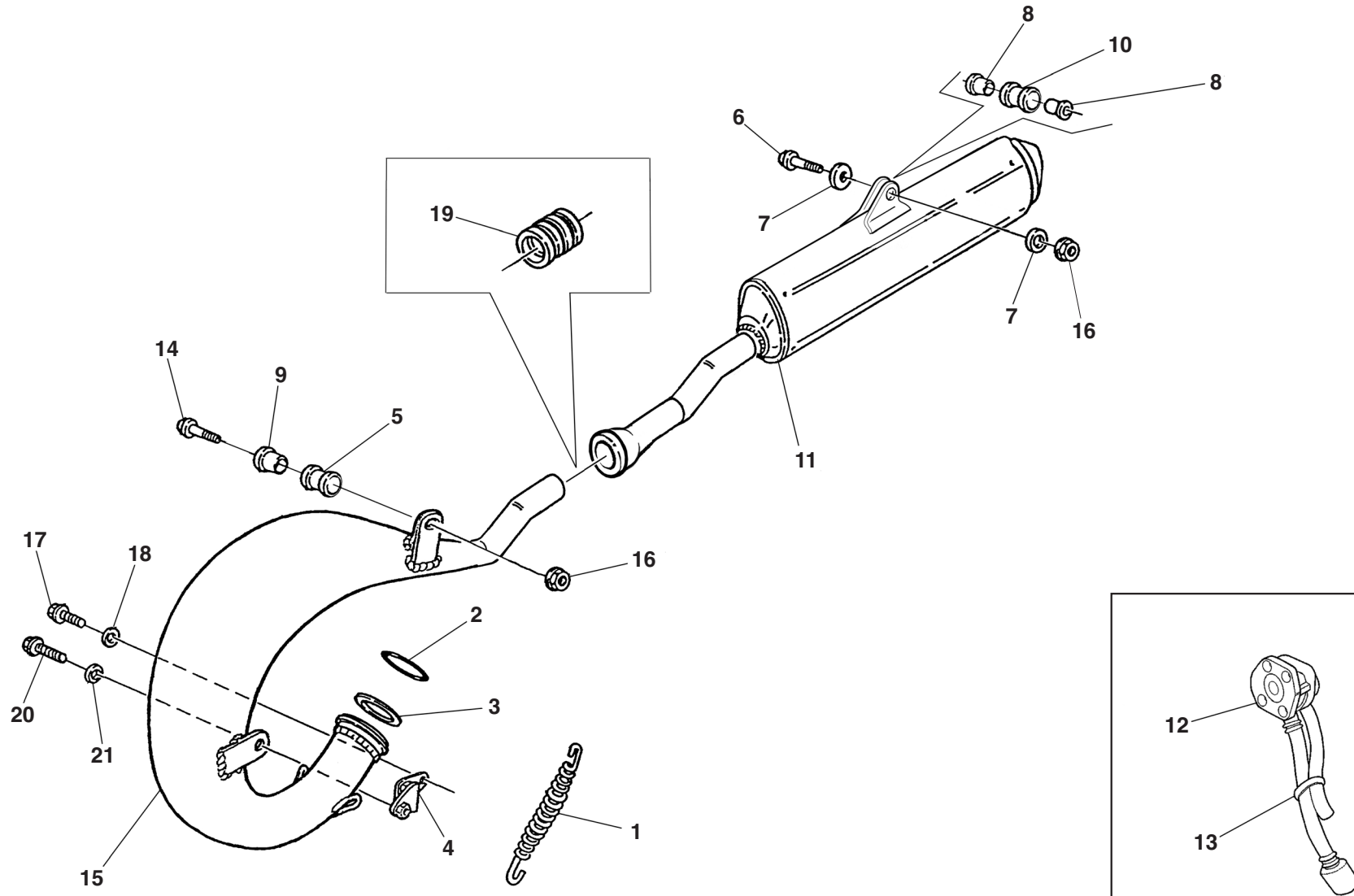
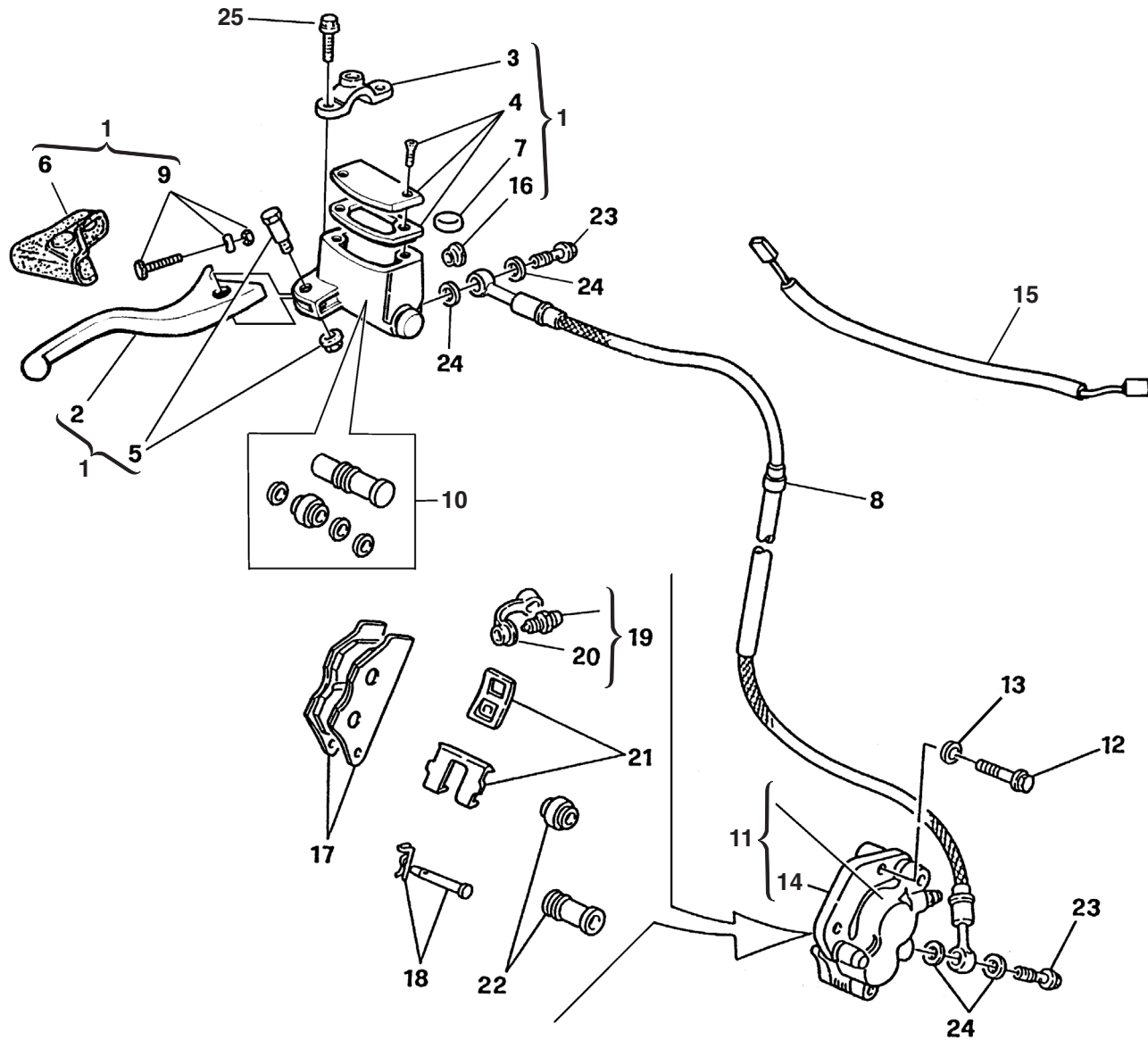

FRENO IDRAULICO ANTERIORE - FRONT HYDRAULIC BRAKE
FREIN HYDRAULIQUE AVANT - VORDERBREMSE
FRENO HIDRAULICO DELANTERO

Note Notes Notes Marke Notas	Pos. No. Index Pos.	N. Cod. Code No. Nr. Code Code Nr N. Cod.	Q.tà Q.ty Q.te M.ge C.ad	DENOMINAZIONE	NAME	DESIGNATION	BESHREIBUNG	DENOMINACION
CU	1	8000 A9347	1	Pompa comando freno ant.	Brake pump	Pompe frein	Bremspumpe	Bomba freno
W	1	8000 A9348	1	Pompa comando freno ant.	Brake pump	Pompe frein	Bremspumpe	Bomba freno
CU	2	8000 A9351	1	Leva	Lever	Levier	Hebel	Palanca
CW	2	8000 A4564	1	Leva	Lever	Levier	Hebel	Palanca
CU	3	8000 A4565	1	Cavallotto	U-bolt	Cavalier	Bügelbolzen	Caballete
CW	3	8000 A4568	1	Cavallotto	U-bolt	Cavalier	Bügelbolzen	Caballete
	4	8000 94126	1	Kit tappo	Plug kit	Bouchon kit	Verschluss Gruppe	Kit tapón
	5	8000 94127	1	Perno	Pin	Pivot	Bolzen	Perno
	6	8000 94128	1	Cappuccio	Cap	Capuchon	Kappe	Capuchón
	7	8000 79099	1	Antiemulsione	Antiemulsion	Antiemulsion	Emulsionwidriger	Antiemulsión
CU	8	8A00 93036	1	Tubo	Pipe	Tuyau	Rohr	Tubo
W	8	8A00 A6242	1	Tubo mandata olio	Oil pipe	Tuyauterie d'huile	Oelrohr	Tubo aceite
	9	8000 A9349	1	Regolazione	Adjuster	Registre	Regler	Regulizador
	10	8000 A9350	1	Flottante	Plunger	Piston	Kolben	Pistón
	11	8000 H0768	1	Pinza freno	Brake caliper	Etrier frein	Bremssattel	Pinza
	12	ZA00 62733	2	Vite	Screw	Vis	Schraube	Tornillo
	13	Z000 56337	2	Rosetta	Washer	Rondelle	Scheibe	Arandela
	14	8000 A7145	1	Supporto	Support	Support	Halterung	Soporte
W	15	8000 A0929	1	Microinterruttore freno anteriore	Control microswitch	Microinterrupteur commande	Microschalter	Microconmutador
	16	8000 49654	1	Oblò	Port-hole	Hublot	Bullaage	Portilla
	17	8000 A7143	1	Coppia pastiglie	Pads pair	Paire plaquettes	Bremsbelagpaar	Pareja pastillas
A	17	8000 H0770	1	Coppia pastiglie	Pads pair	Paire plaquettes	Bremsbelagpaar	Pareja pastillas
	18	8000 A0932	1	Perni	Pin	Pivot	Bolzen	Perno
	19	8000 A0931	1	Spurgo	Drain	Vidange	Entleerung	Purga
	20	8000 53259	1	Parapolvere	Boots	Para-poudr	Schutzhaube	Para-polvo
	21	8000 A7144	1	Molla-lamierino	Spring-steel clip	Ressort	Feder	Rresorte
	22	8000 79066	1	Cuffie	Boots	Poussiers	Haube	Gorro
	23	U000 57155	2	Vite	Screw	Vis	Schraube	Tornillo
	24	8000 21480	4	Rosetta	Washer	Rondelle	Scheibe	Arandela
	25	8000 62729	2	Vite	Screw	Vis	Schraube	Tornillo

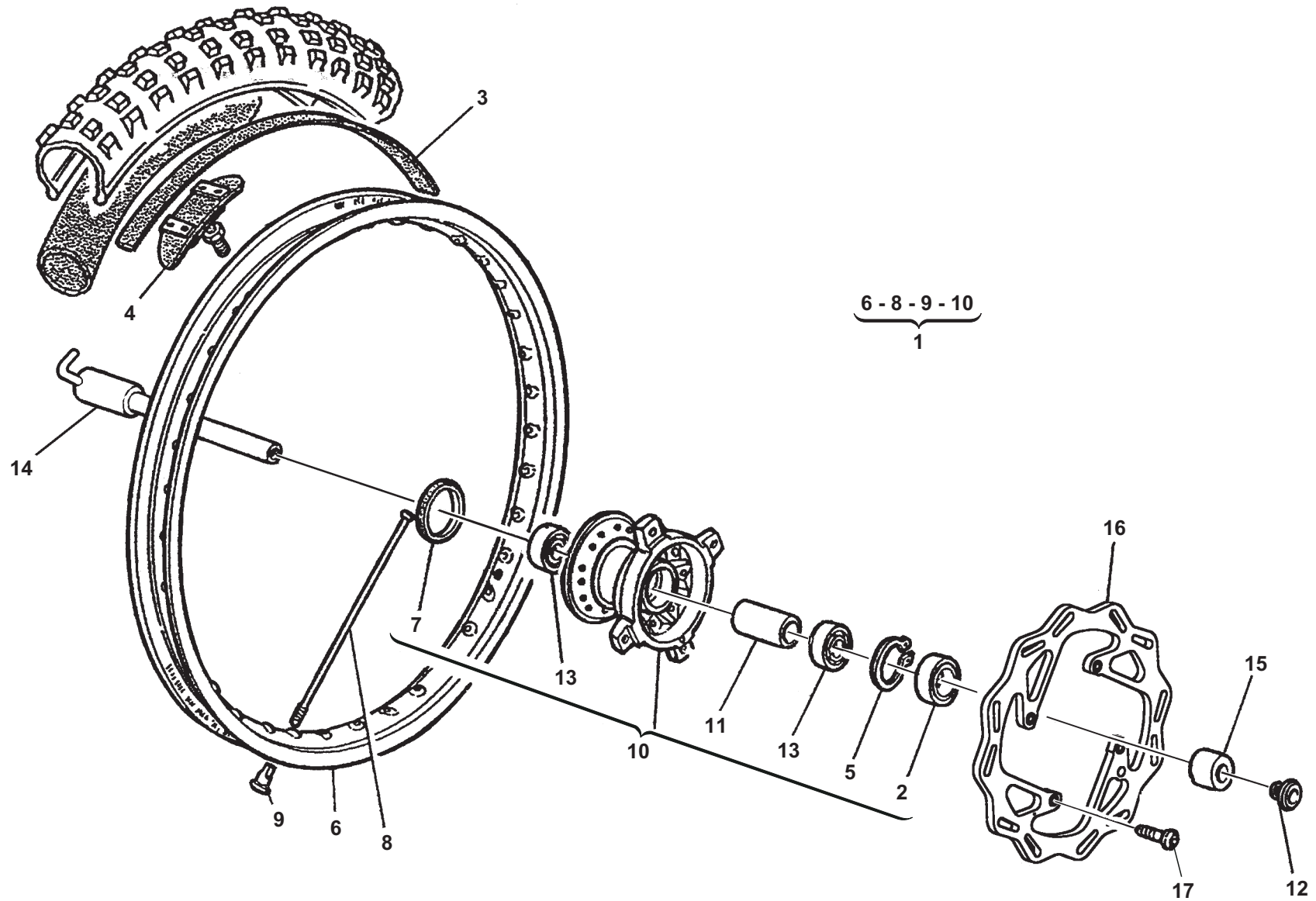

WR 125/2013
CR 125/2013

TAVOLA - DRAWING
TABLE - BILD - TABLA

23

RUOTA ANTERIORE - FRONT WHEEL
ROUE AVANT - VORTERRAD
RUEDA DELANTERA



Note Notes Notes Marke Notas	Pos. No. Index Pos.	N. Cod. Code No. Nr. Code Code Nr N. Cod.	Q.tà Q.ty Q.te M.ge C.ad	DENOMINAZIONE	NAME	DESIGNATION	BESHREIBUNG	DENOMINACION
C	1	8A00 H1360	1	Ruota nuda per ricambi	Front wheel assy	Roue antérieure complète	Vorder Rad Kpl.	Rueda anterior completa
W	1	8A00 H2272	1	Ruota nuda per ricambi	Front wheel assy	Roue antérieure complète	Vorder Rad Kpl.	Rueda anterior completa
	2	8000 22966	1	Anello di tenuta	Seal ring	Bague de retenue	Dichtring	Anillo de retención
	3	8000 13346	1	Fascia copriraggi	Rim strip	Bande	Band	Banda
	4	8000 49036	1	Staffa fermacopertone	Bracket	Etrier	Buegel	Brida
	5	66N0 21270	1	Anello elastico	Snap ring	Circlip	Sprengring	Anillo elástico
C	6	8A00 H1361	1	Cerchio (1,6"x21")	Rim (1,6"x21")	Jante (1,6"x21")	Felge (1,6"x21")	Llanta (1,6"x21")
W	6	80A0 H2079	1	Cerchio (1,6"x21")	Rim (1,6"x21")	Jante (1,6"x21")	Felge (1,6"x21")	Llanta (1,6"x21")
	7	8000 H6187	1	Anello di tenuta (ø28xø50x5 mm)	Seal ring (ø28xø50x5 mm)	Bague d'étancheite (ø28xø50x5 mm)	Dichtring (ø28xø50x5 mm)	Anillo de retención (ø28xø50x5 mm)
	8	8000 H1362	36	Raggio ALPINA	Spoke ALPINA	Bras ALPINA	Speiche ALPINA	Radio ALPINA
	9	8000 A6208	36	Nipplo ALPINA	Nipple ALPINA	Nipple ALPINA	Nippel ALPINA	Nipple ALPINA
	10	8000 H1363	1	Mozzo completo	Hub assy	Moyeau compl.	Radnabe, Kpl.	Cubo compl.
	11	8000 H6186	1	Distanziale	Spacer	Entretoise	Distanzstück	Separador
	12	8000 96933	1	Vite	Screw	Vis	Schraube	Tornillo
	13	8000 84938	2	Cuscinetto a sfere	Ball bearing	Roulement à billes	Kugellager	Cojinete de bolas
	14	8000 H1547	1	Perno ruota	Pin	Pivot	Bolzen	Perno ruota
	15	8A00 96930	1	Distanziale	Spacer	Entretoise	Distanzstück	Separador
	16	8000 H0192	1	Disco freno (ø260 mm)	Brake disc (ø260 mm)	Disque frein (ø260 mm)	Bremsscheibe (ø260 mm)	Disco freno (ø260 mm)
	17	YA00 55241	4	Vite	Screw	Vis	Schraube	Tornillo

RUOTA POSTERIORE - REAR WHEEL
ROUE ARRIERE - HINTERRAD
RUEDA TRASERA

Note Notes Notes Marke Notas	Pos. No. N. Index Pos.	N. Cod. Code No. Nr. Code Code Nr N. Cod.	Q.tà Q.ty Q.te M.ge C.ad	DENOMINAZIONE	NAME	DESIGNATION	BESHREIBUNG	DENOMINACION
C	1	8000 H7499	1	Ruota nuda per ricambi	Back wheel assy	Roue postérieure complète	Hinter Rad Kpl.	Rueda posterior completa
W	1	8B00 H1530	1	Ruota nuda per ricambi	Back wheel assy	Roue postérieure complète	Hinter Rad Kpl.	Rueda posterior completa
	2	8000 89572	2	Anello di tenuta Ø32xØ47x7	Seal ring Ø32xØ47x7	Bague de retenuta Ø32xØ47x7	Dichtring Ø32xØ47x7	Anillo de retención Ø32xØ47x7
C	3	8000 10777	1	Fascia copriraggi	Rim strip	Bande	Band	Banda
W	3	8000 01688	1	Fascia copriraggi	Rim strip	Bande	Band	Banda
	4	8000 54073	1	Staffa fermacopertone	Bracket	Etrier	Buegel	Brida
C	5	8000 H1365	1	Cerchio (2,15"x19")	Rim (2,15"x19")	Jante (2,15"x19")	Felge (2,15"x19")	Llanta (2,15"x19")
W	5	80A0 H1532	1	Cerchio (2,15"x18")	Rim (2,15"x18")	Jante (2,15"x18")	Felge (2,15"x18")	Llanta (2,15"x18")
C	6	8000 H1366	18	Raggio lato corona	Spoke ring gear side	Bras côte couronne	Speiche Kranzseite	Radio lado corona
C	6	8000 H1367	18	Raggio lato disco	Spoke brake side	Bras côte frein	Speiche Bremsseite	Radio lado disco
W	6	8000 H1533	18	Raggio lato disco	Spoke brake side	Bras côte frein	Speiche Bremsseite	Radio lado disco
W	6	8000 H1534	18	Raggio lato corona	Spoke ring gear side	Bras côte couronne	Speiche Kranzseite	Radio lado corona
	7	8000 A6209	36	Nipplo	Nipple	Nipple	Nippel	Nipple
	8	8000 H1368	1	Mozzo completo	Hub assy	Moyeau compl.	Radnabe, Kpl.	Cubo compl.
	9	8000 H6189	1	Distanziale	Spacer	Entretoise	Distanzstück	Separador
	10	8B00 26846	1	Cuscinetto	Bearing	Roulement	Kugellager	Cojinete
	11	66N0 21272	1	Anello elastico	Snap ring	Circlip	Sprengring	Anillo elástico
	12	8000 96938	2	Distanziale	Spacer	Entretoise	Distanzstück	Separador
	13	Y000 93072	1	Dado	Nut	Ecrou	Mutter	Tuerca
	14	8000 H4977	1	Disco freno (Ø240 mm)	Brake disc (Ø240 mm)	Disque frein (Ø240 mm)	Bremsscheibe (Ø240 mm)	Disco freno (Ø240 mm)
	15	8000 55878	4	Vite	Screw	Vis	Schraube	Tornillo
R	16	8C00 96837	1	Corona (Z=49)	Ring gear (Z=49)	Couronne (Z=49)	Kranz (Z=49)	Corona (Z=49)
R	16	8E00 96837	1	Corona (Z=51)	Ring gear (Z=51)	Couronne (Z=51)	Kranz (Z=51)	Corona (Z=51)
R	16	8F00 96837	1	Corona (Z=52)	Ring gear (Z=52)	Couronne (Z=52)	Kranz (Z=52)	Corona (Z=52)
S	16	8D00 96837	1	Corona (Z=50)	Ring gear (Z=50)	Couronne (Z=50)	Kranz (Z=50)	Corona (Z=50)
	17	8000 H0158	6	Vite	Screw	Vis	Schraube	Tornillo
	18	8000 43928	6	Dado	Nut	Ecrou	Mutter	Tuerca
	19	8000 H1548	1	Perno	Pin	Pivot	Bolzen	Perno
	20	8A00 26846	2	Cuscinetto	Bearing	Roulement	Kugellager	Cojinete
C	21	8A00 56768	1	Catena Regina 5/8"x1/4" (112 maglie)	Chain Regina 5/8"x1/4" (112 maglie)	Chaîne Regina 5/8"x1/4" (112 maglie)	Kette Regina 5/8"x1/4" (112 maglie)	Cadena Regina 5/8"x1/4" (112 maglie)
W	21	8000 A6261	1	Catena Regina 5/8"x1/4" (112 maglie)	Chain Regina 5/8"x1/4" (112 maglie)	Chaîne Regina 5/8"x1/4" (112 maglie)	Kette Regina 5/8"x1/4" (112 maglie)	Cadena Regina 5/8"x1/4" (112 maglie)
C	22	8000 56767	1	Giunto Regina	Coupling Regina	Joint Regina	Kupplung Regina	Junta Regina
W	22	8000 A6262	1	Giunto Regina	Regina Coupling	Joint Regina	Kupplung Regina	Junta Regina

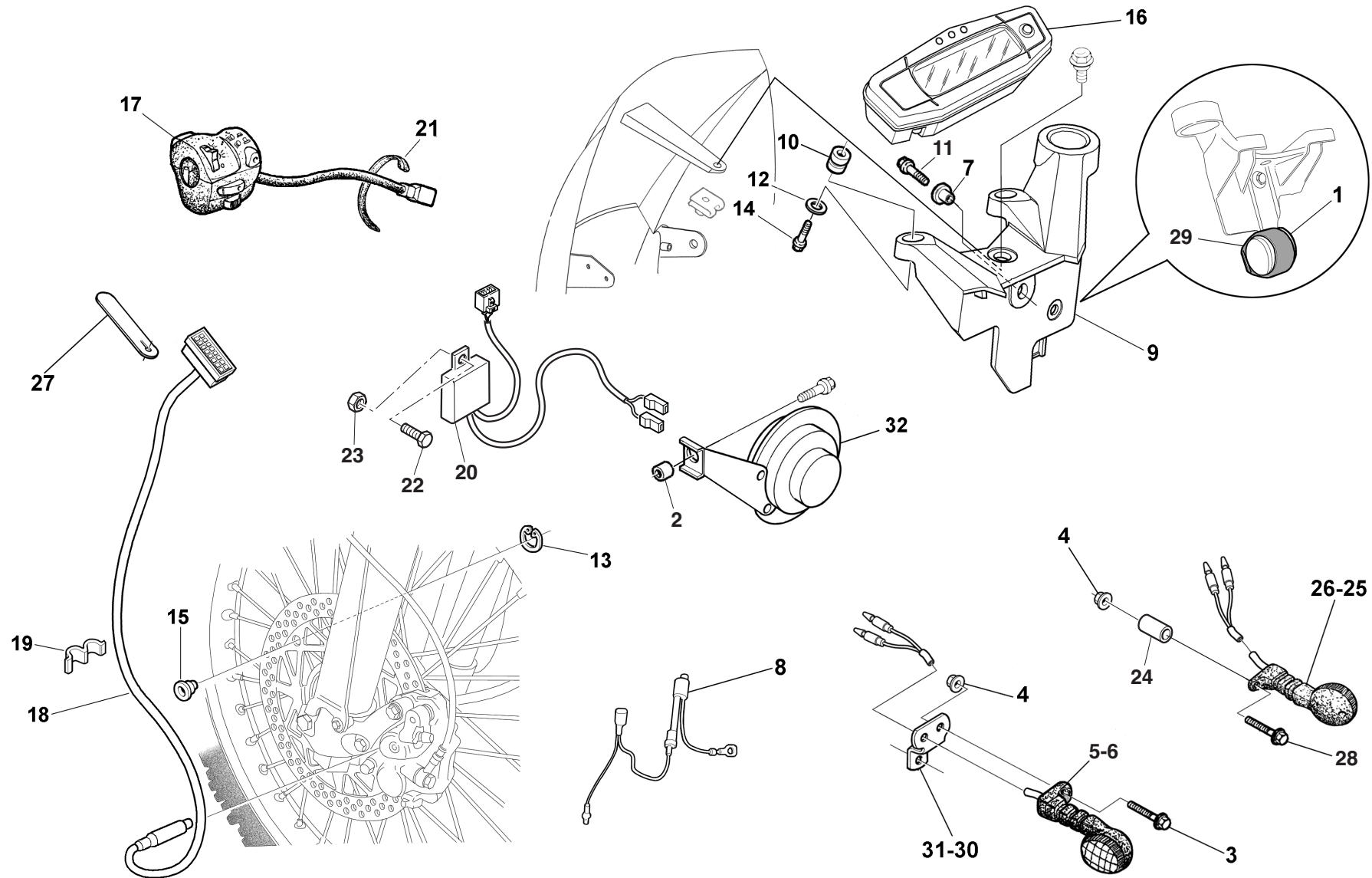

**STRUMENTO DIGITALE, INDICATORI DI DIREZIONE, AVVISATORE ACUSTICO - DIGITAL INSTRUMENT,
BLINKERS, HORN-INSTRUMENT DIGITAL, CLIGNOTANTS, SIGNAL ACOUSTIQUE - DIGITAL TACHOMETER,
BLINKERS, HUPE-INSTRUMENTO DIGITAL, INTERMITENTES, AVISADOR ACUSTICO**
TAVOLA - DRAWING
TABLE - BILD - TABLA

25

Note Notes Notes Marke Notas	Pos. No. N. Index Pos.	N. Cod. Code No. Nr. Code Code Nr N. Cod.	Q.tà Q.ty Q.te M.ge C.ad	DENOMINAZIONE	NAME	DESIGNATION	BESHREIBUNG	DENOMINACION
	1	8000 57511	1	Intermittenza	Flash device	Intermittence	Blinkgeber	Intermitencia
	2	8000 A6638	1	Distanziale	Spacer	Entretoise	Distanzstück	Distanciadador
	3	Z000 62727	4	Vite	Screw	Vis	Schraube	Tornillo
	4	Z000 44240	4	Dado	Nut	Ecrou	Mutter	Tuerca
	5	8000 A0228	1	Indicatore ant. Sx	Front L.H. blinker	Clignotant G. avant	Vordere L. Blinker	Intermitente I. del.
	6	8000 A0227	1	Indicatore ant. Dx	Front R.H. blinker	Clignotant D. avant	Vordere R. Blinker	Intermitente D. del.
	7	8000 69282	1	Bussola	Bushing	Douille	Buchse	Buje
	8	8000 H1017	1	Resistenza (protez. strumento)	Resistance	Résistance	Widerstand	Resistencia
	9	8000 H0315	1	Piastra	Plate	Plaque	Platte	Placa
	10	8000 H0316	2	Gommino	Rubber pad	Pièce caoutchouc	Gummistück	Junta de goma
	11	8000 67997	1	Vite	Screw	Vis	Schraube	Tornillo
	12	62ND 15548	2	Rosetta	Washer	Rondelle	Scheibe	Arandela
	13	66NO 21200	1	Anello elastico	Snap ring	Circlip	Sprengring	Anillo elástico
	14	8A00 H0534	2	Vite	Screw	Vis	Schraube	Tornillo
	15	8000 99775	1	Magnete	Magnet	Aimant	Magnet	Imán
	16	8000 H0136	1	Strumento digitale	Digital instrument	Instrument digital	Digital Tachometer	Instrumento digital
X	17	8000 A0634	1	Commutatore compl.	Switch compl.	Commutateur compl.	Kombischalter kpl.	Conmutador compl.
	18	8B00 99652	1	Sensore magnetico	Sensor	Palpeur	Sensor	Sensòr
	19	8000 H0644	2	Clip fissaggio connettori	Connectors fastening clip	Clip de fixation connecteurs	Befestigungsclip Verbinder	Fijación conectores
	20	8000 H5762	2	Alimentatore avvisatore acustico	Cable	Cable	Kabel	Cable
	21	8000 71578	4	Fascetta	Clamp	Collier	Schelle	Banda
	22	8000 62726	1	Vite	Screw	Vis	Schraube	Tornillo
	23	8000 44240	1	Dado	Nut	Ecrou	Mutter	Tuerca
	24	8000 69429	2	Bussola	Bushing	Douille	Buchse	Buje
	25	8000 A0229	1	Indicatore post. Dx	Front R.H. blinker	Clignotant D. avant	Vordere R. Blinker	Intermitente D. tras.
	26	8000 A0230	1	Indicatore post. Sx	Front L.H. blinker	Clignotant G. avant	Vordere L. Blinker	Intermitente I. tras.
	27	8000 92668	3	Fascetta	Clamp	Collier	Schelle	Banda
	28	Z000 62728	2	Vite	Screw	Vis	Schraube	Tornillo
	29	8000 37599	1	Supporto elastico	Elastic holder	Support	Halterung	Soporte
	30	8000 A6642	1	Piastrina Dx	R.H.Plate	Plaque D.	R. Platte	Placa D.
	31	8A00 A6642	1	Piastrina Sx	L.H.Plate	Plaque G.	L. Platte	Placa I.
	32	8000 H0221	1	Avvisatore acustico	Horn for front fork	Signal acoustique	Hupe	Avisador acustico

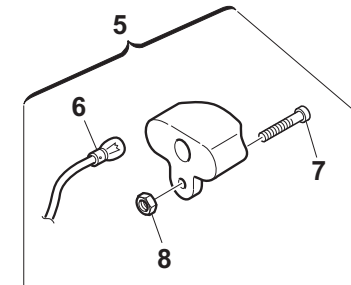
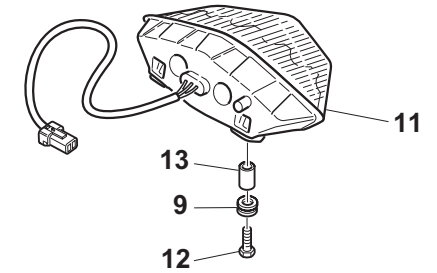
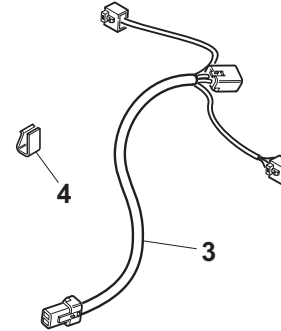
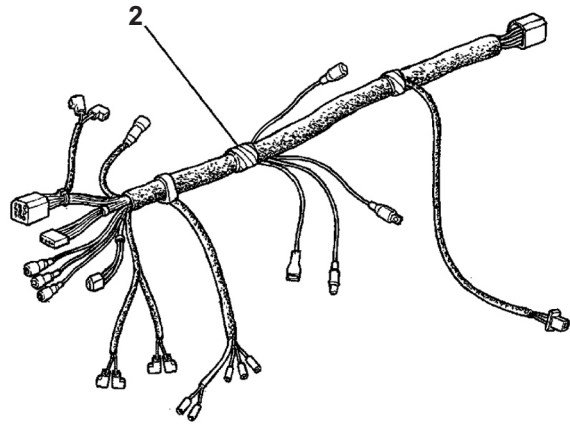

17 - 20 - 21
10

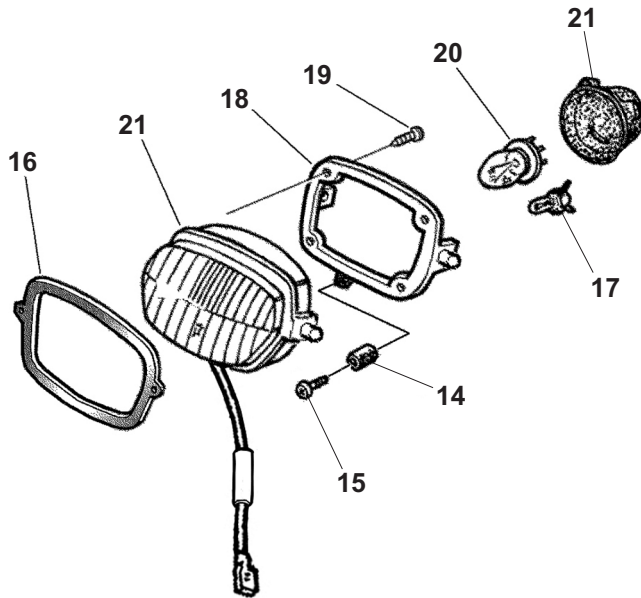

WR USA

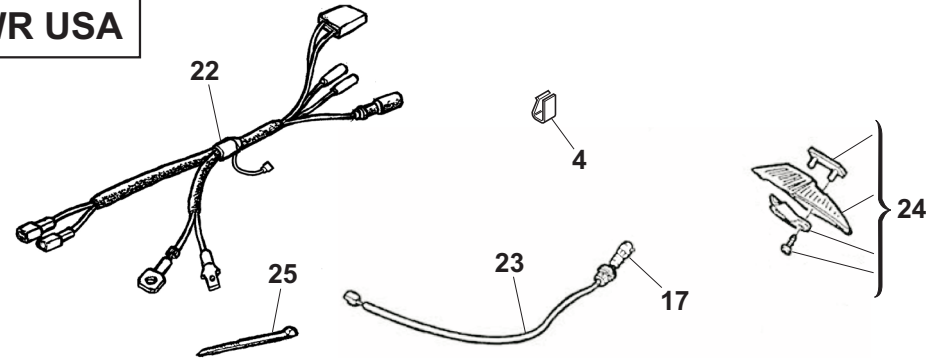

**GRUPPO CAVI, PARTI ELETTRICHE - MAIN WIRING HARNESS, ELECTRICAL PARTS -
CABLES PRINCIPAL, PARTIES ELECTRIQUES - KABEL, ELEKTRISCHE KOMPONENTE -
GRUPO PRINCIPAL CABLES, PARTES ELECTRICAS**

Note Notes Marke Notas	Pos. No. N. Index Pos.	N. Cod. Code No. Nr. Code Code Nr N. Cod.	Q.tà Q.ty Q.te M.ge C.ad	DENOMINAZIONE	NAME	DESIGNATION	BESHREIBUNG	DENOMINACION
W	1	8000 56444	8	Fascetta	Clamp	Collier	Schelle	Banda
C	2	8000 H0290	1	Gruppo principale cavi	Cable assy	Câbles compl.	Kabel Kpl.	Grupo principal cables
U	2	8000 H4844	1	Gruppo principale cavi (USA)	Cable assy (USA)	Câbles compl.(USA)	Kabel Kpl. (USA)	Grupo principal cables (USA)
WX	2	8000 H4019	1	Gruppo principale cavi	Cable assy	Câbles compl.	Kabel Kpl.	Grupo principal cables
WX	3	8000 H2018	1	Cavo posteriore	Cable	Cable	Kabel	Cable
WX	4	8000 72494	1	Molletta	Tube clip	Ressort	Feder	Resorte
WX	5	8B00 A0212	1	Luce targa	Plate Illumination	Éclairage De Plaque	Kennzeichen-Beleuchtung	Iluminación Placa
WX	6	8000 36230	1	Lampadina (12V-5W)	Bulb (12V-5W)	Ampoule (12V-5W)	Lampe (12V-5W)	Lámpara (12V-5W)
WX	7	60ND 07330	1	Vite (M5x16 mm)	Screw (M5x16 mm)	Vis (M5x16 mm)	Schraube(M5x16 mm)	Tornillo (M5x16 mm)
WX	8	61ND 15192	1	Dado	Nut	Ecrou	Mutter	Tuerca
WX	9	8000 95128	2	Antivibrante	Silent-block	Antivibration	Schwingungsdämpfer	Anti-vibrador
U	10	8000 A5566	1	Gruppo ottico compl.	Optical group assy.	Groupe optique compl.	Optische Gruppe Kpl.	Grupo óptico completo
WX	10	8000 H0475	1	Gruppo ottico compl.	Optical group assy.	Groupe optique compl.	Optische Gruppe Kpl.	Grupo óptico completo
WX	11	8000 H1418	1	Fanale posteriore completo	Tail light	Feux arrière	Hinterleuchte	Faro trasero
WX	12	8000 62728	2	Vite	Screw	Vis	Schraube	Tornillo
WX	13	8000 H1735	2	Distanziale	Spacer	Entretoise	Distanzstück	Separador
W	14	8A00 A1051	1	Distanziale	Spacer	Entretoise	Distanzstück	Separador
W	15	60ND 02487	1	Vite	Screw	Vis	Schraube	Tornillo
W	16	8000 A1053	1	Guarnizione	Gasket	Garniture	Dichtung	Junta
W	17	8000 26694	1	Lampada (12V-3 W)	Lamp (12V-3 W)	Lampe (12V-3 W)	Lampe (12V-3 W)	Lamparilla (12V-3 W)
W	18	8000 A6484	1	Fissaggio fanale	Headlamp holder	Support pour phare-avant	Vorderleuchtehalterung	Soporte faro delantero
W	19	Z000 A6635	4	Vite	Screw	Vis	Schraube	Tornillo
W	20	8000 20137	1	Lampada (12V-35/35W)	Lamp (12V-35/35W)	Lampe (12V-35/35W)	Lampe (12V-35/35W)	Lamparilla (12V-35/35W)
W	21	8000 A5567	1	Gruppo ottico	Optical group	Groupe optique	Optische Gruppe	Grupo óptico
U	22	8000 H0061	1	Gruppo cavi (ANTERIORE)	Cable assy (FRONT)	Cables compl. (AVANT)	Kabel Kpl. (VORDERE)	Grupo cables (DELANTERO)
U	23	8000 71221	1	Gruppo cavi (POSTERIORE)	Cable assy (REAR)	Cables compl. (ARRIERE)	Kabel Kpl. (HINTERE)	Grupo cables (TRASERO)
U	24	8000 71213	1	Fanale posteriore completo	Tail light	Feux arrière	Hinterleuchte	Faro trasero
U	25	8000 34002	2	Fascetta	Clamp	Collier	Schelle	Banda

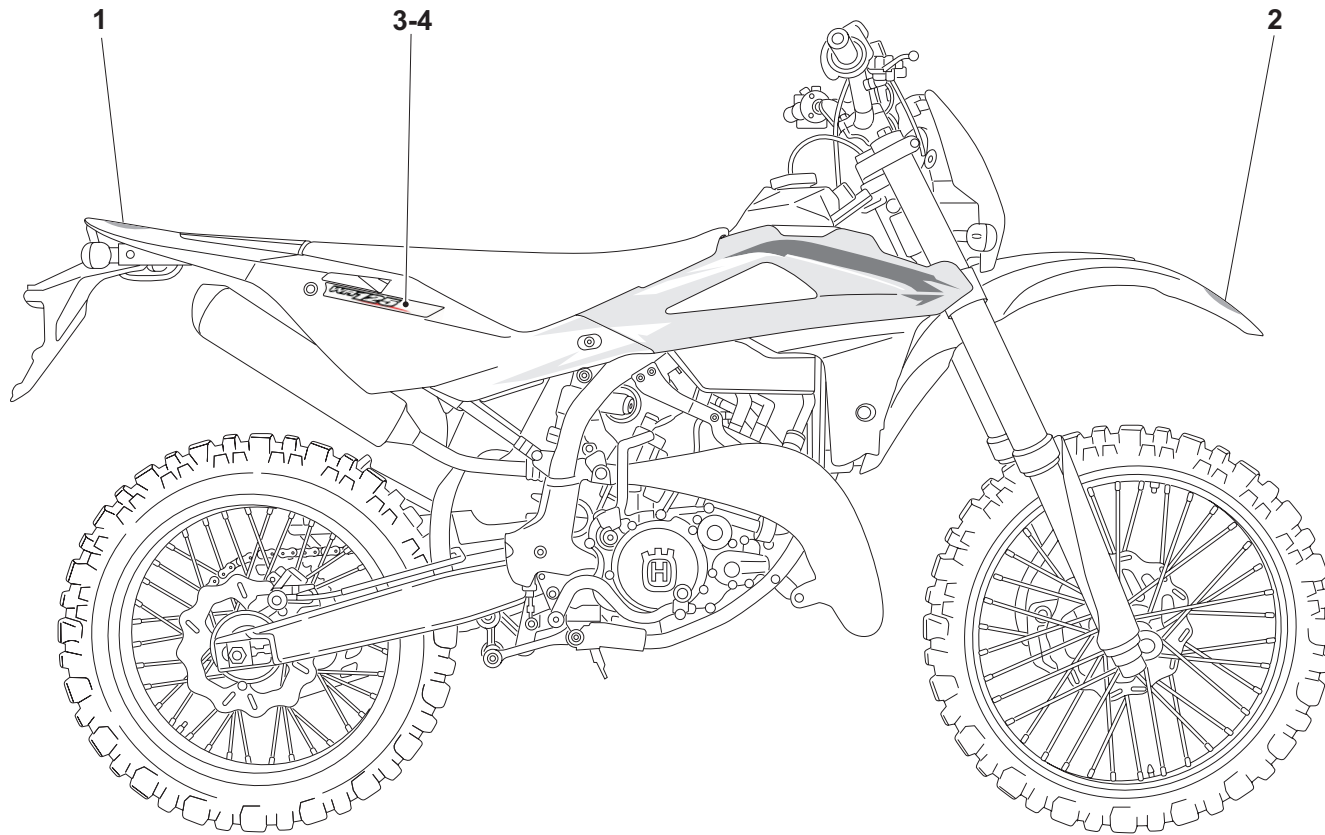

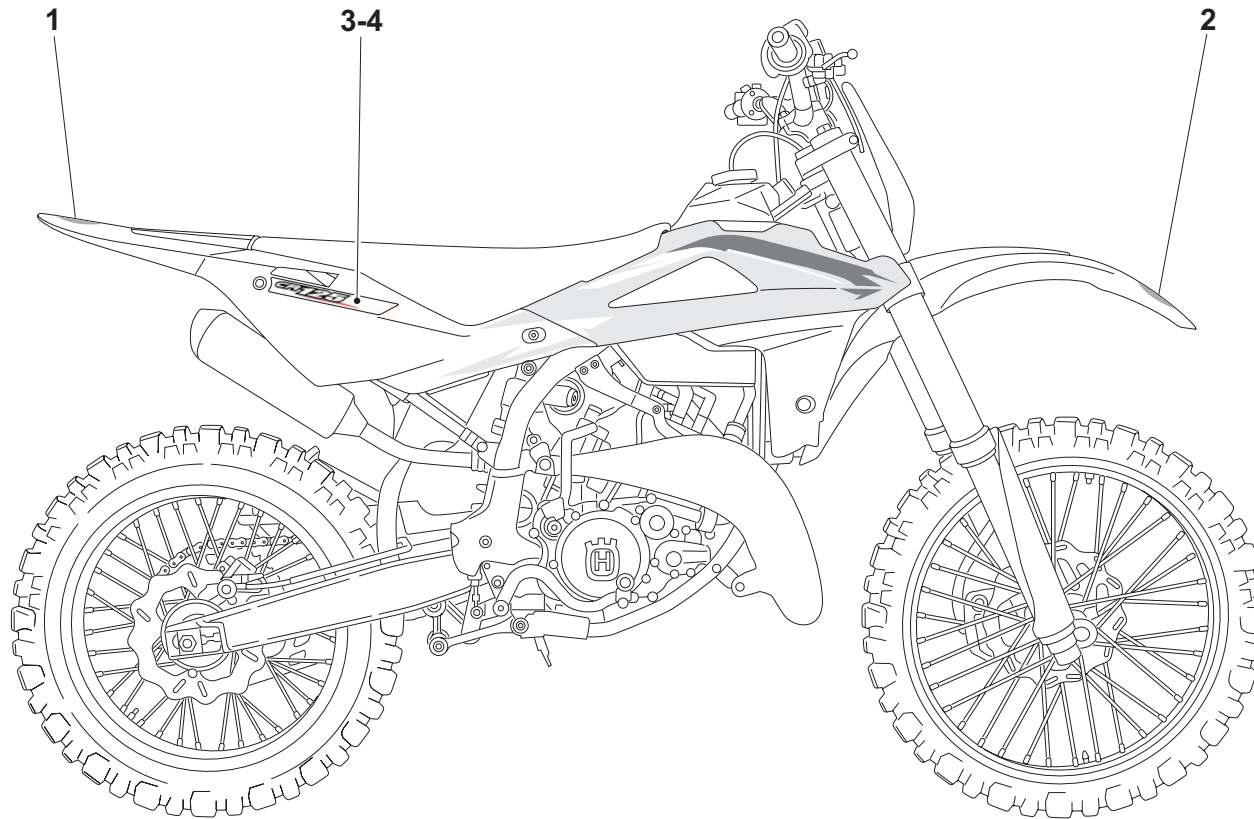

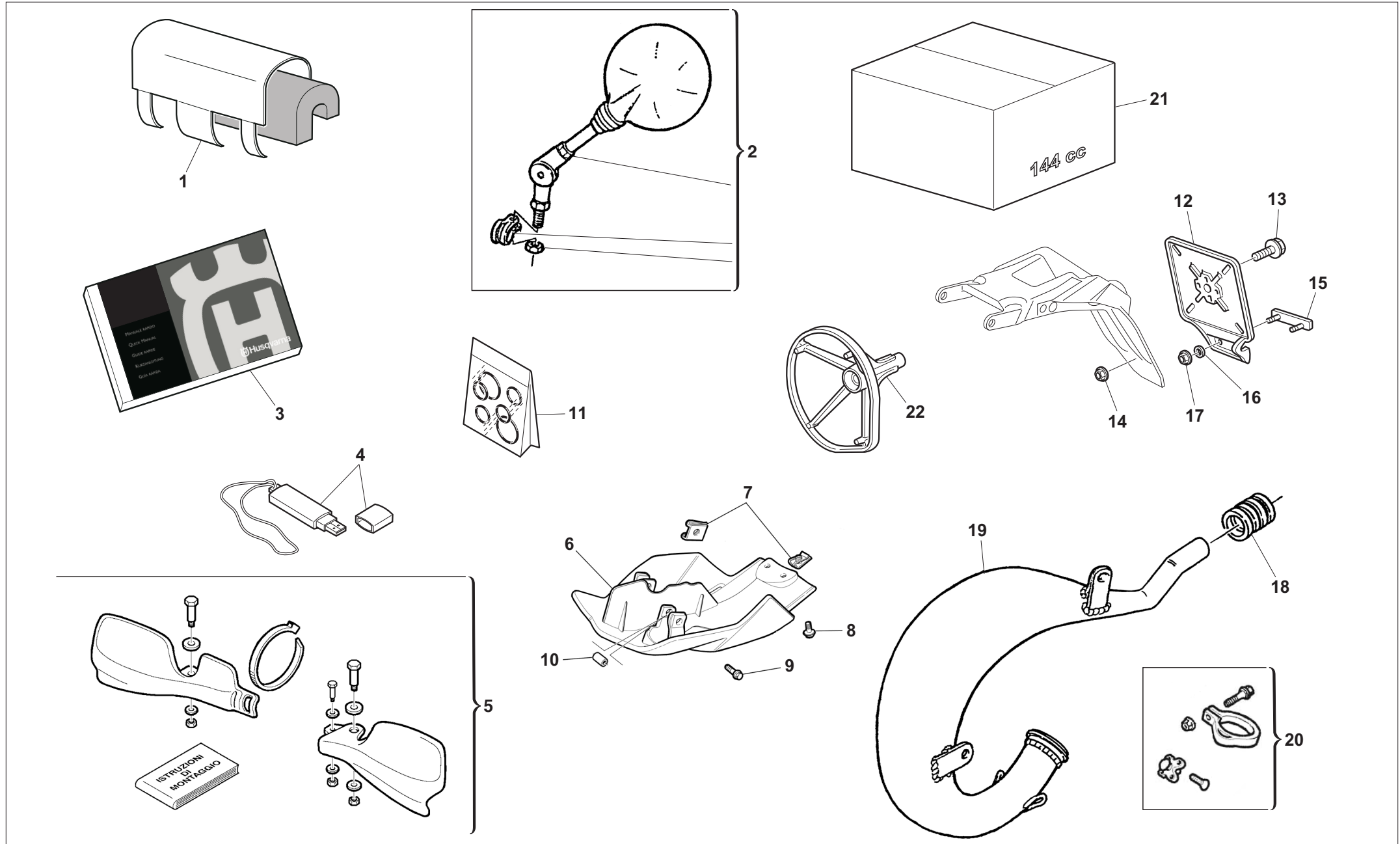

WR 125/2013
CR 125/2013

TAVOLA - DRAWING
TABLE - BILD - TABLA

29

DOTAZIONE - EQUIPMENT
EQUIPEMENT - DOTIERUNG
EQUIPAMIENTO



Note Notes Notes Marke Notas	Pos. No. N. Index Pos.	N. Cod. Code No. Nr. Code Code Nr N. Cod.	Q.tà Q.ty Q.te M.ge C.ad	DENOMINAZIONE	NAME	DESIGNATION	BESHREIBUNG	DENOMINACION
	1	8538941	1	Protezione manubrio	Guard	Protection	Schutz	Protección
W	2	8A00 H1673	1	Specchietto retrov. Sx	L.H. Driving mirror	Rétroviseur G.	L. Rückspiegel	Espejo retrovisor Izq.
W	2	8000 H1673	1	Specchietto retrov. Dx	R.H. Driving mirror	Rétroviseur D.	R. Rückspiegel	Espejo retrovisor Der.
X	3	8538751	1	Libretto uso e manutenzione	Owner's manual	Emploi d'entretien	Betriebsanleitung	Manual uso y manten.
X	4	8538736	1	Chiavetta USB	USB key	Mémoire USB	USB Speicher-stick	Memoria USB
USA	4	8538737	1	Chiavetta USB	USB key	Mémoire USB	USB Speicher-stick	Memoria USB
W	5	8000 H3965	1	Kit paramani	Guards Kit	Kit protection	Schutzgruppe kpl	Grupo protection
	6	8000 H0120	1	Paramotore	Engine guard	Garde moteur	Motorschutz	Para motor
	7	U000 46893	4	Dado a graffetta	Nut	Ecrou	Mutter	Tuerca
	8	8A00 A8423	2	Vite flangiata M6-L12	Flange bolt M6-L12	Boulon de bride M6-L12	Flanschschraube M6-L12	Perno de reborde M6-L12
	9	ZA00 67545	2	Vite M6-L35	Screw M6-L35	Vis M6-L35	Schraube M6-L35	Tornillo M6-L35
	10	8000 H3012	2	Distanziale	Spacer	Entretoise	Distanzstück	Separador
W	11	8000 H0052	1	Kit carburatore	Carburetor kit	Kit carburateur	Vergaser Kit	Kit carburador
C	11	8000 H7527	1	Kit getti	Jet kit	Kit gicleurs	Düse Kit	Kit chiclé
U	11	8000 H0052	1	Kit carburatore	Carburetor kit	Kit carburateur	Vergaser Kit	Kit carburador
W	12	8000 H3018	1	Portatarga	Licence plate holder	Portebalai	Schildträger	Portamatrícula
W	13	ZA00 67997	2	Vite M5-L16	Screw M5-L16	Vis M5-L16	Schraube M5-L16	Tornillo M5-L16
W	14	Z000 56443	2	Dado	Nut	Ecrou	Mutter	Tuerca
W	15	8000 73834	1	Catadiottro	Reflector	Catadioptrique	Rückstrahler	Catafaros
W	16	62ND 15547	2	Rosetta	Washer	Rondelle	Scheibe	Arandela
W	17	Z000 40717	2	Dado	Nut	Ecrou	Mutter	Tuerca
	18	8000 92788	1	Manicotto	Sleeve	Fourreau	Hülse	Manguito
W	19	80A0 H2116	1	Tubo di scarico libero	Exhaust pipe	Tuyau d'échapp.	Auspuffrohr	Tubo de escape
C	20	8000 B1530	1	Kit gancio partenza	Starting hook, kit	Kit crochet pour départ	Abfahrthacken	Gancho por salida
USA	21	8000 H2995	1	Kit 144cc	Kit 144cc	Kit 144cc	Kit 144cc	Kit 144cc
	22	8000 69549	1	Gabbia filtro	Cleaner cage	Cage pour filtre	Filterkafig	Caja filtro